

Brickcom

Megapixel Cube Network Camera

CB-100A/WCB-100A

Quick Installation Guide

Quality Service Group



Read Before You Use

1. Power off the camera device immediately if it starts smoking or smells unusual.



2. Power off the camera device immediately if the camera is exposed to rain or liquid.



3. Do not set the camera device near any heat sources. (Ex: television and oven)

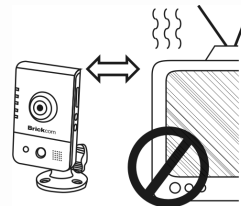

4. Keep the camera device away from direct sunlight.

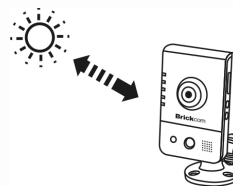

5. Do not set the camera device over the specific operating temperature.



6. Do not set the camera device in any wet and humid environments.



7. Do not set the camera device on unsteady surfaces.



8. Do not attempt to dismantle the camera device.

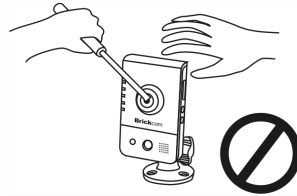

9. Do not drop or hit the camera device.

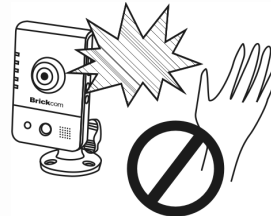

10. Do not use the camera device when there is lightning.

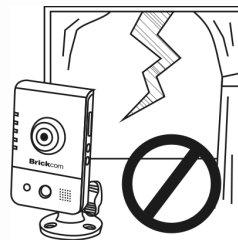



1. Check Package Contents

a. CB-100A/ WCB-100A

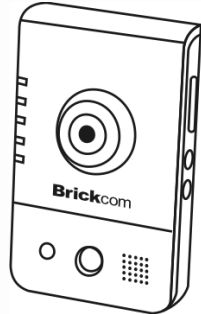

b. Product CD

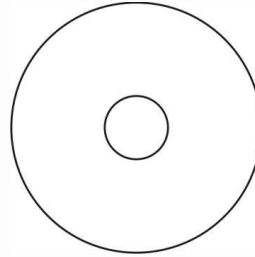

c. Camera Stand



d. White Flat RJ-45 cable(1.5m)

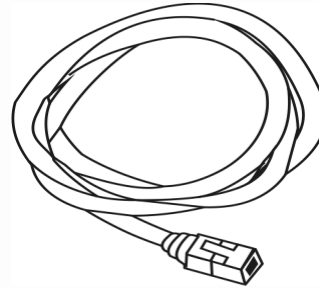

e. Warranty Card



f. Power Adapter

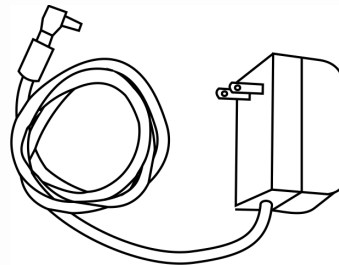

g. Quick Guide

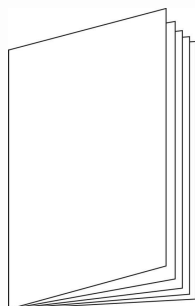



2. Device Description

<Front & Rear view>

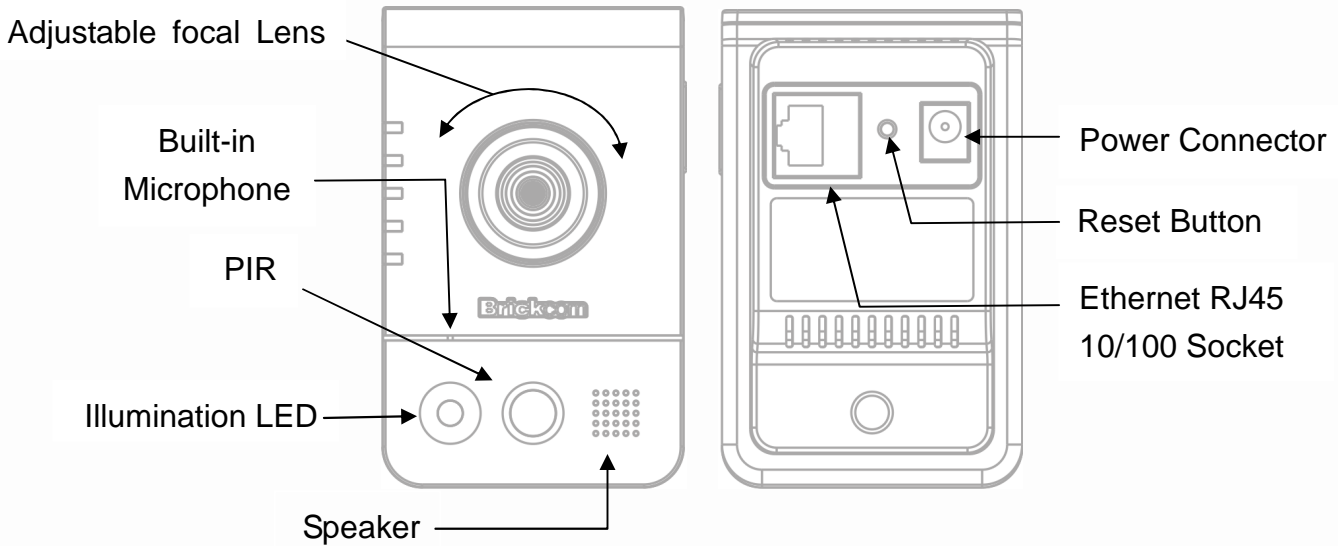

<Side view>

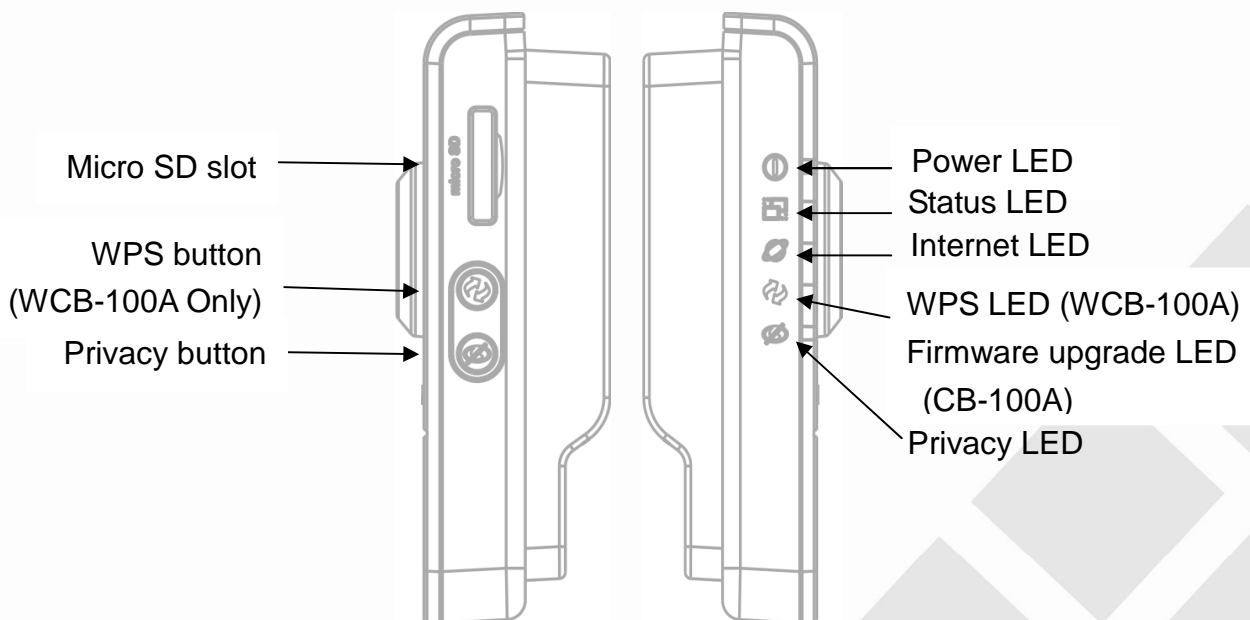



3. System Requirements

Operating System:

Microsoft Windows XP Home Edition SP2

Microsoft Windows XP Professional SP2

Computer:

IBM PC/AT Compatible

CPU:

Pentium 3GHz or faster

Memory:

1024 MB or more

Monitor:

1024 x 768 pixels or more, 24-bit True color or better

Network Interface:

10/100Mbps Network interface card must be installed

Web Browser:

Microsoft Internet Explorer 6.0 SP2 or higher

Adobe Reader:

Adobe Reader 8.0 or higher

Audio:

The audio function will not work if a sound card is not installed in the PC. Audio may be interrupted depending on network traffic.



4. Camera Connection

Basic Connection

1. Connect the supplied power cable from the camera to the power outlet.
2. Connect the camera to a switch via Ethernet cable.

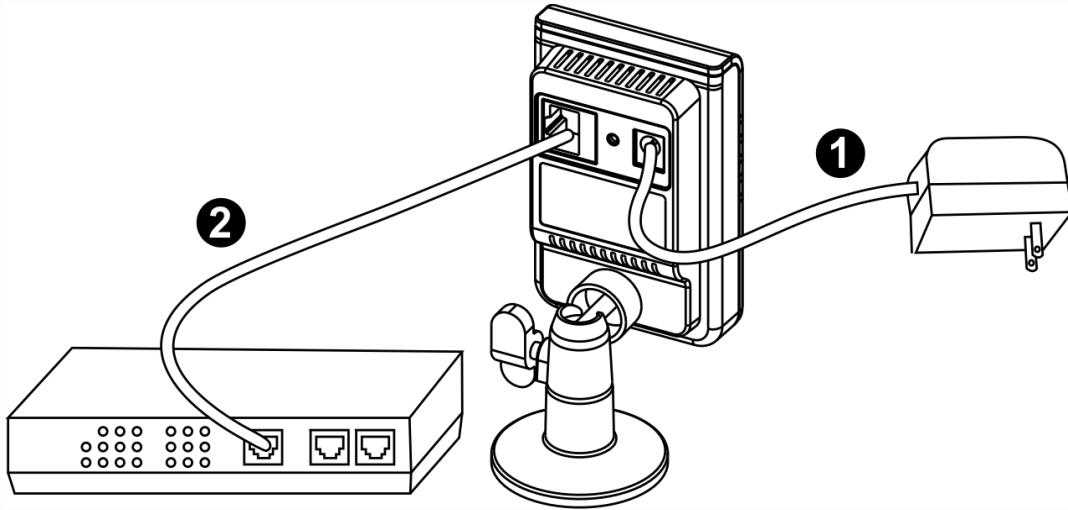



5. Setup the Network Camera

1. Insert the Installation CD into the CD-ROM driver. Run Auto-run Tool directly from the CD-ROM to start the installation. When installing the Brickcom software kit for the first time, select the desired language for the interface. The available languages are listed in the scroll box. Click “Install” and follow the steps to install the easy configuration wizard on the desired computer.



2. In the Install Shield Wizard dialog box, click <Next> to continue.

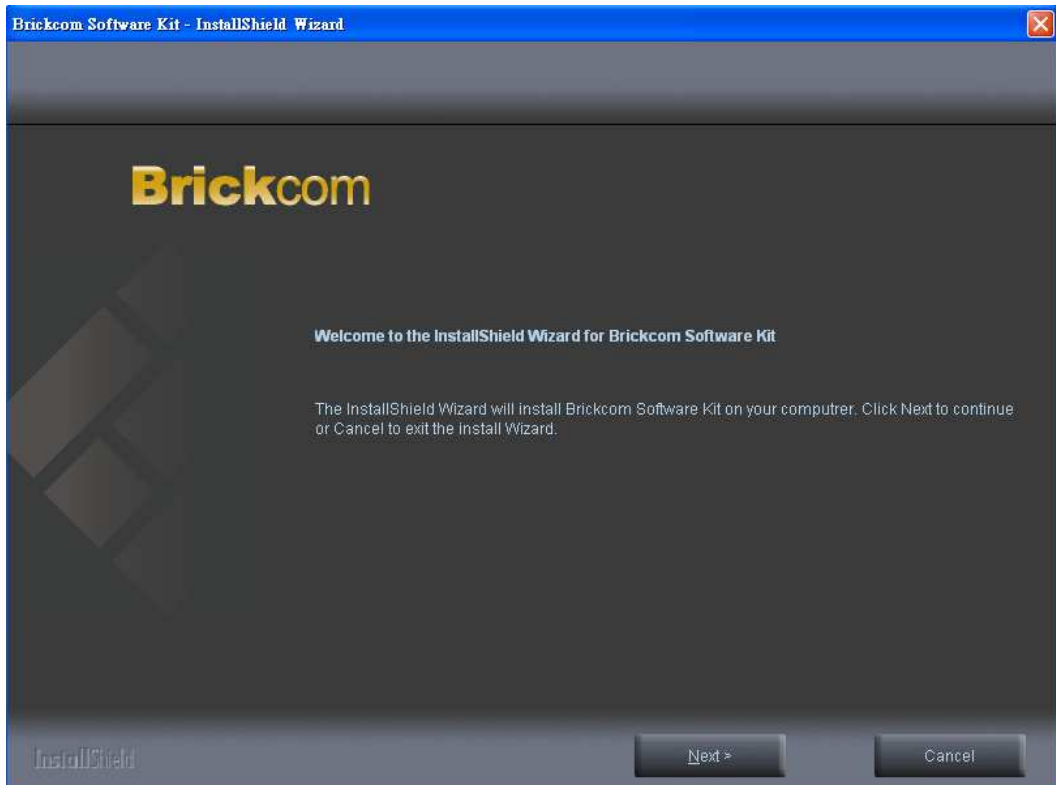

3. Read the End-User License Agreement and check the option "I accept the terms of the license agreement". Click <Next> to continue.

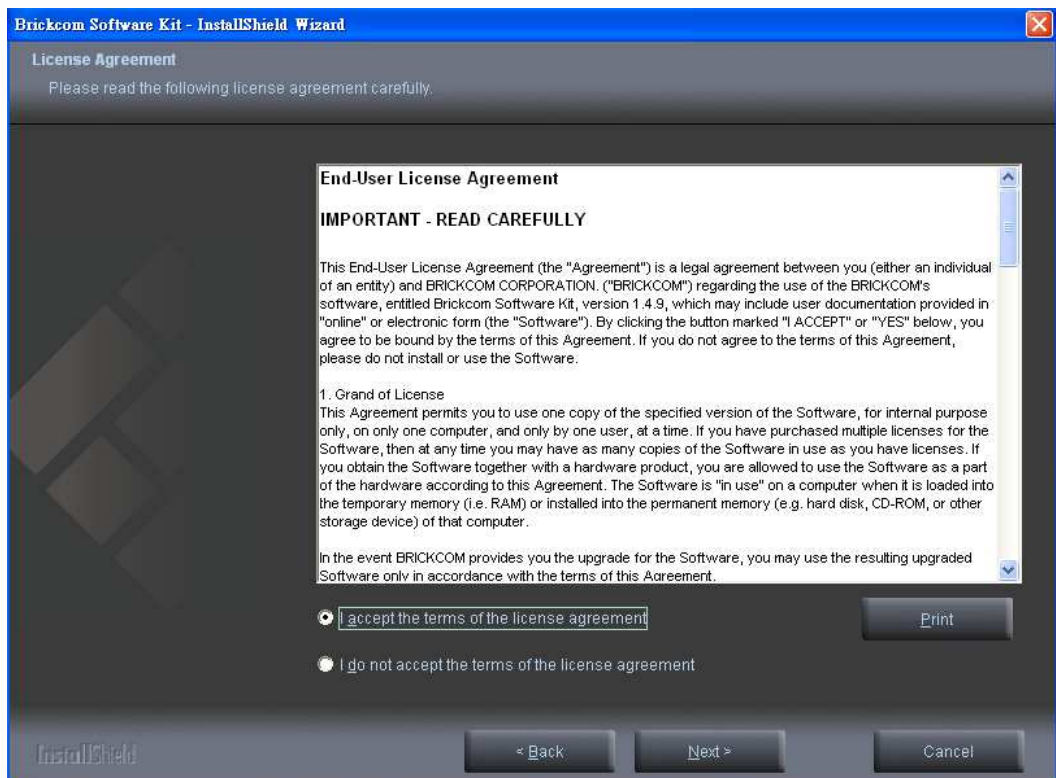

4. Select the appointed folder where setup will install files to. Click **<Change>** to modify the installation directory. Click **<Next>** to continue.

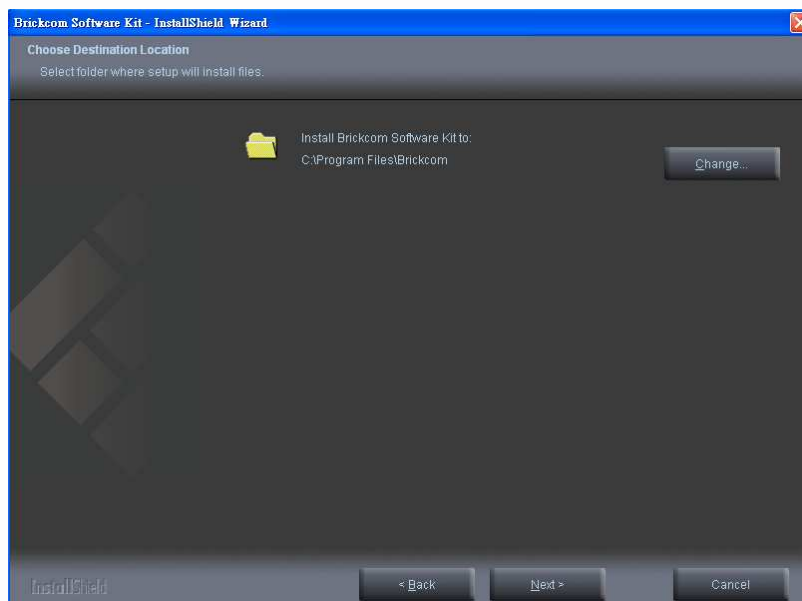

5. Select either "Complete" setup type or "Custom" setup type to install the system.

- a. **If COMPLETE SETUP TYPE is selected:**

- i. **All program features** will be installed into the default directory. Check the option "**Complete**" and then click **<Next>**.

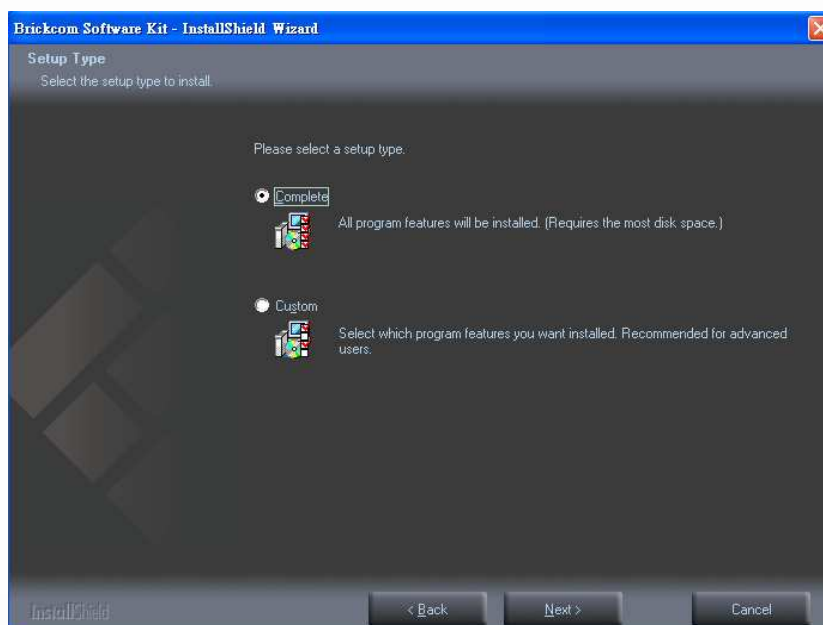

Select to create shortcuts. Click <Next> to continue.

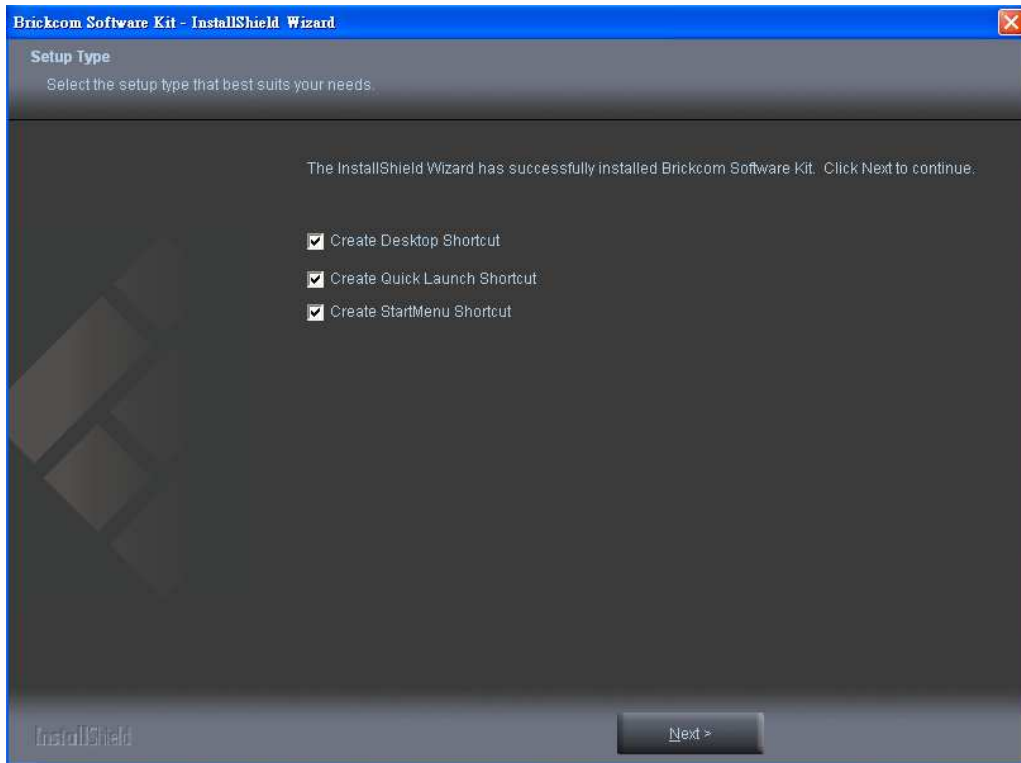

The installation information will be displayed. Click <Next> to continue.

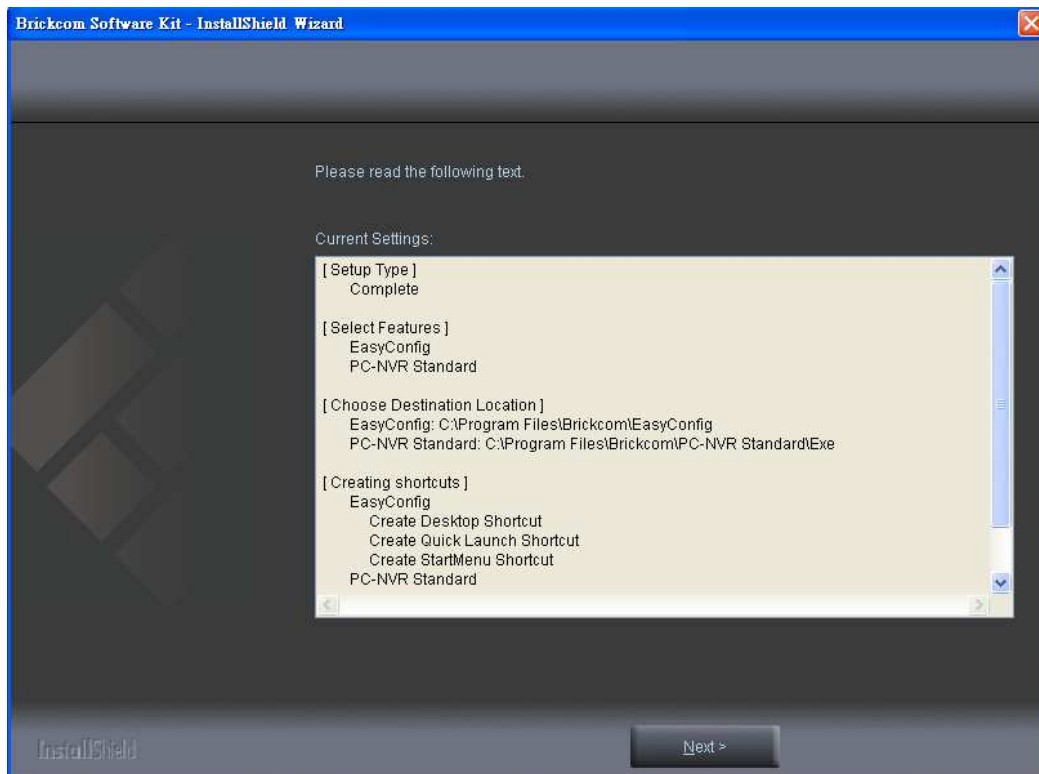

b. If **CUSTOM SETUP TYPE** is selected:

i. This option is recommended for advanced users. It can be used to install the system to a preferred directory or to select specific program feature(s).

ii. Check the option “**Custom**”, and then click <Next>.

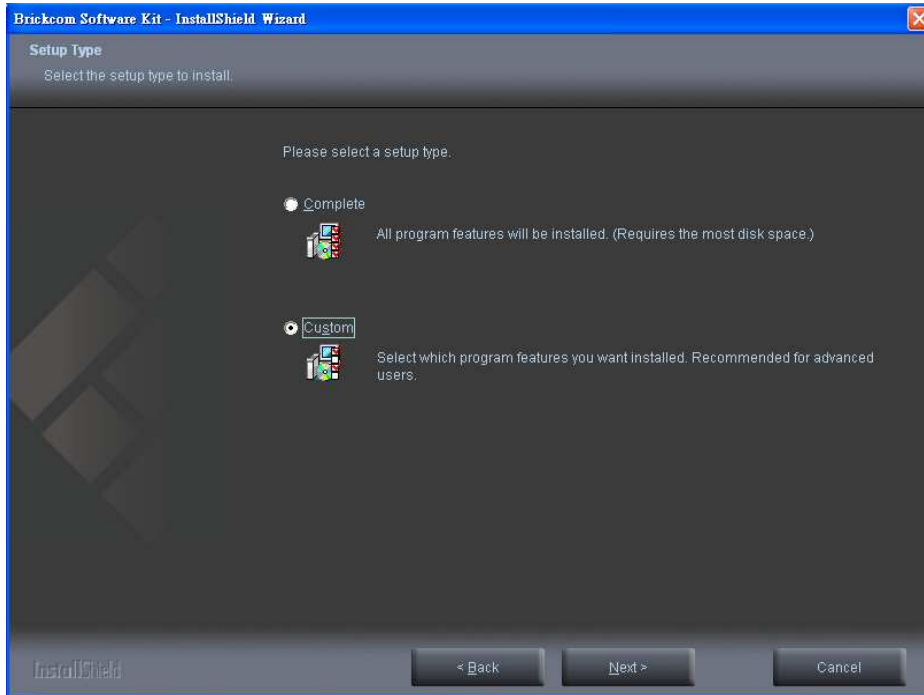

iii. Select the features to install. Click <Next> to continue.

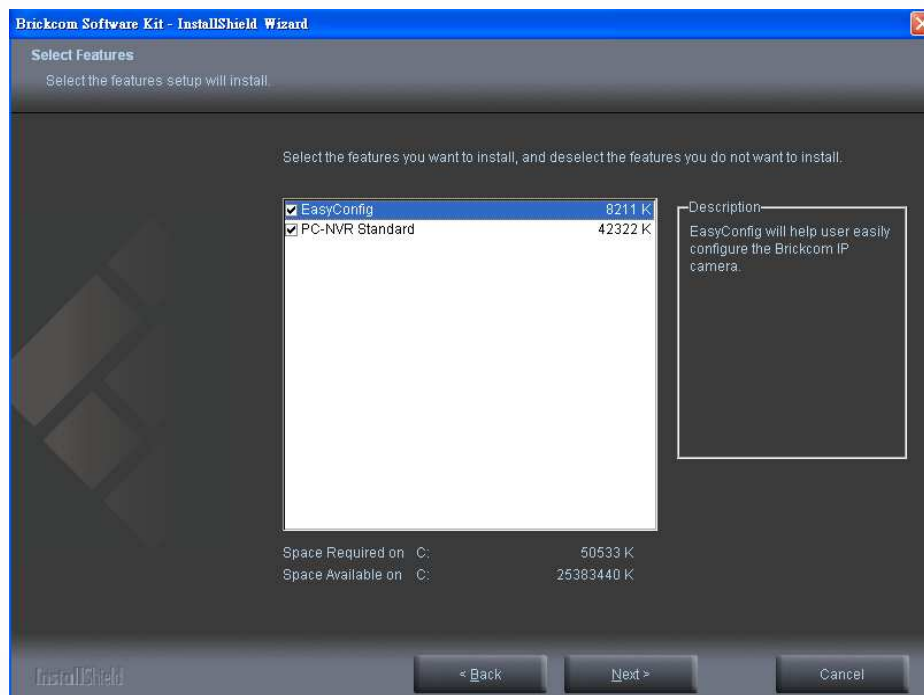

Select the appointed folder where setup will install files to. Click **<Change>** to modify the installation directory. Click **<Next>** to continue.

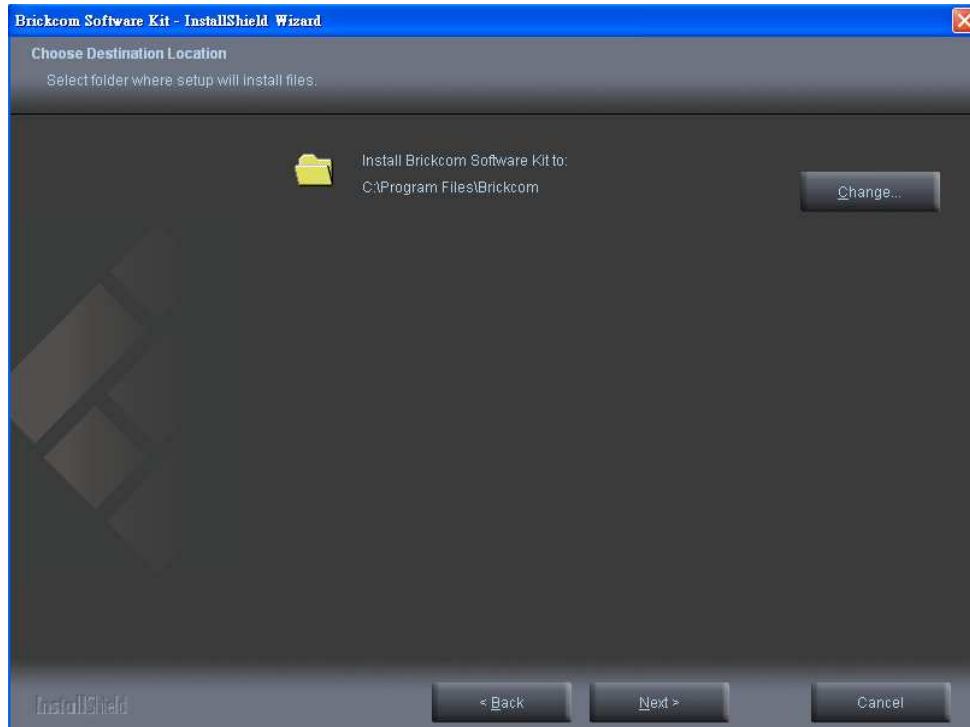

iv. Select to create shortcuts. Click **<Next>** to continue.

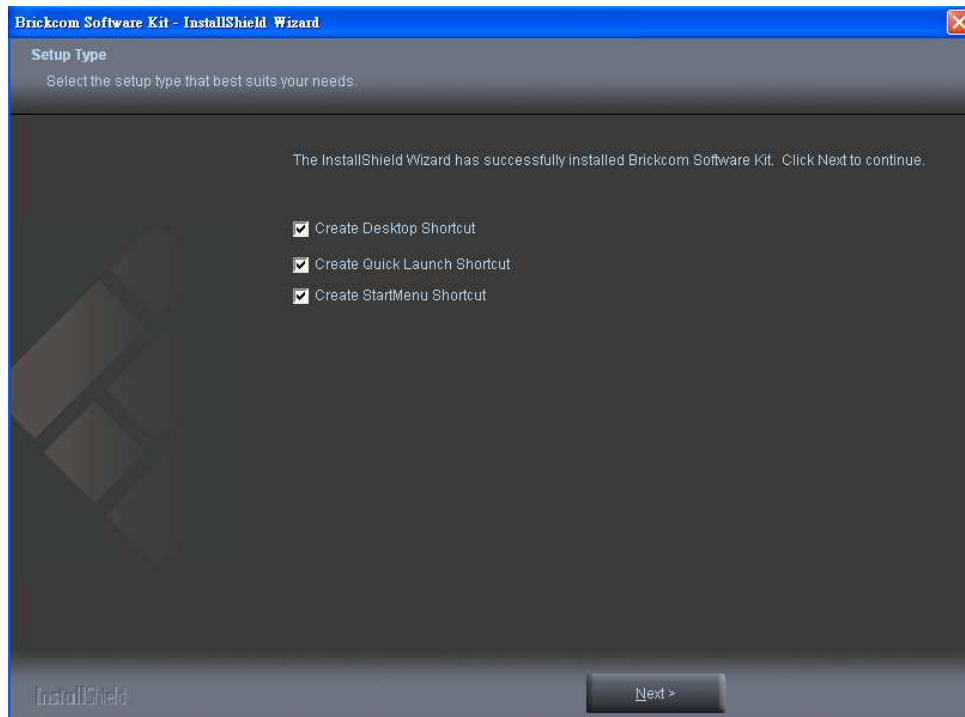

- v. The installation information will be displayed. Click <Next> to continue.

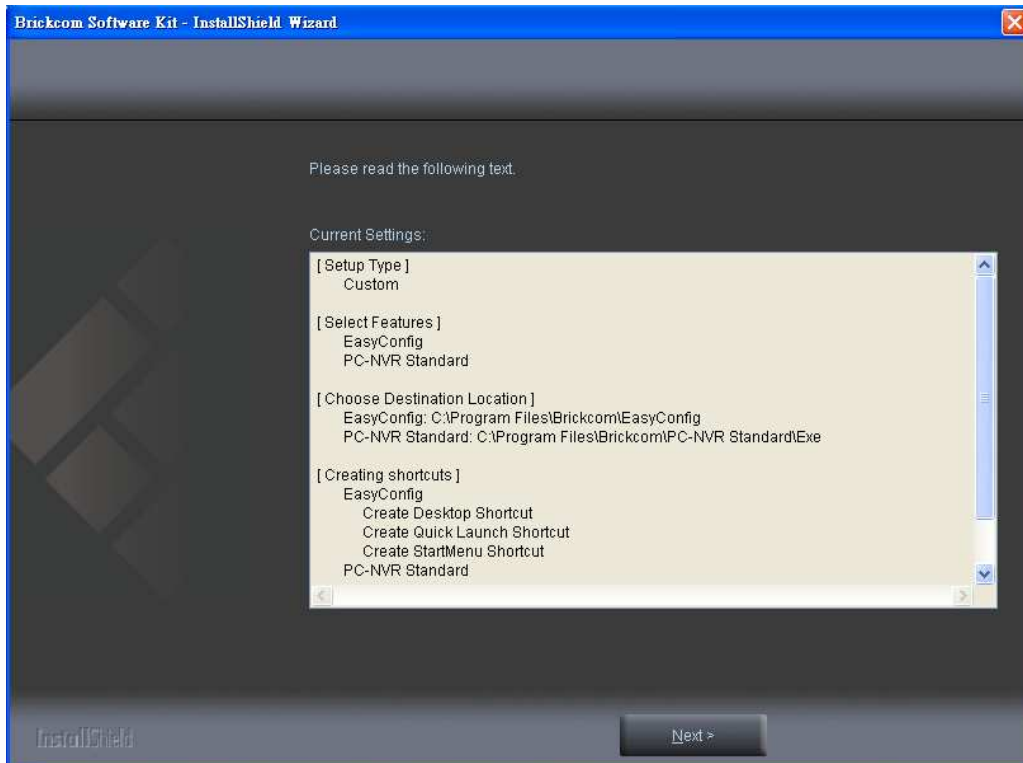

6. Select either EasyConfig or PC-NVR Standard to launch. If the PC-NVR program is launched, please refer to the PC-NVR user manual.

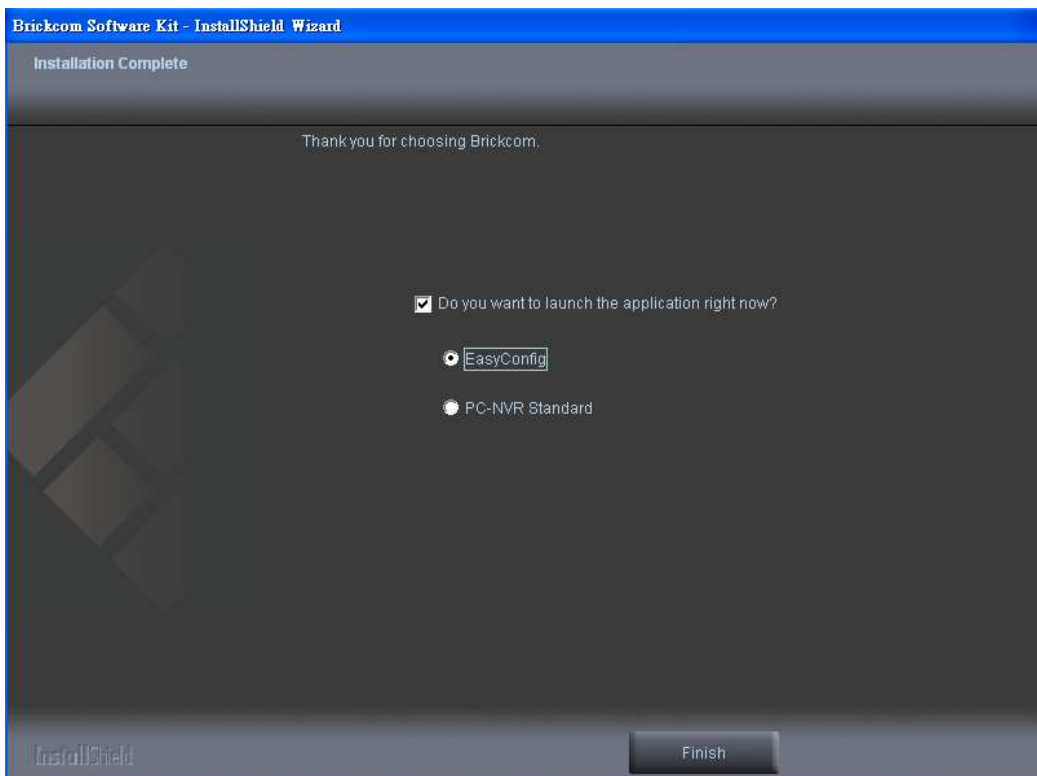

EasyConfig

To launch EasyConfig, select EasyConfig from the start menu. If Complete setup type was used in software installation, an EasyConfig icon was installed on the desktop. Double click to open the icon.



If Custom setup type was used in software installation and an EasyConfig icon was not installed on the desktop, the program should be installed under C:\Program Files\Brickcom\EasyConfig unless the program was saved to a preferred directory.

1. Click <Start> to continue. The program will automatically search for the network camera in the intranet.

 **Note** - Check <Skip the hardware installation guide> to skip the hardware connection checking. If the user wants to check the hardware installation settings, do not check the option box.



Brickcom

Connection

1 Plug one end of the supplied network cable into your network switch or router.

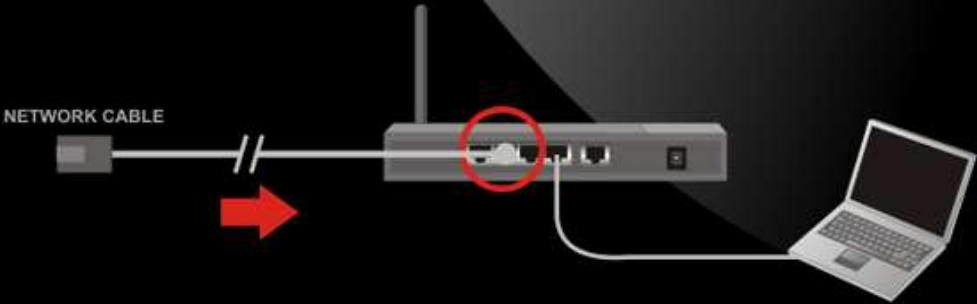

NETWORK CABLE

Diagram illustrating step 1: A network cable is being plugged into the Ethernet port of a network switch or router. The router is connected to a laptop. A red circle highlights the Ethernet port on the router, and a red arrow points to the network cable being inserted.

Navigation buttons: Previous (left arrow) and Next (right arrow).

Brickcom

2 Plug the other end of the supplied network cable into the camera's Ethernet port.

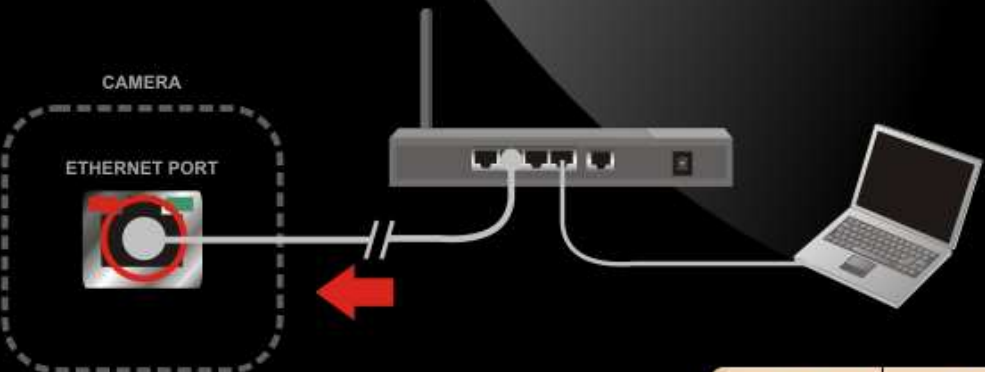

CAMERA

ETHERNET PORT

Diagram illustrating step 2: The other end of the network cable is being plugged into the Ethernet port of the camera. The camera is connected to the router. A red arrow points to the camera's Ethernet port.

Navigation buttons: Previous (left arrow) and Next (right arrow).

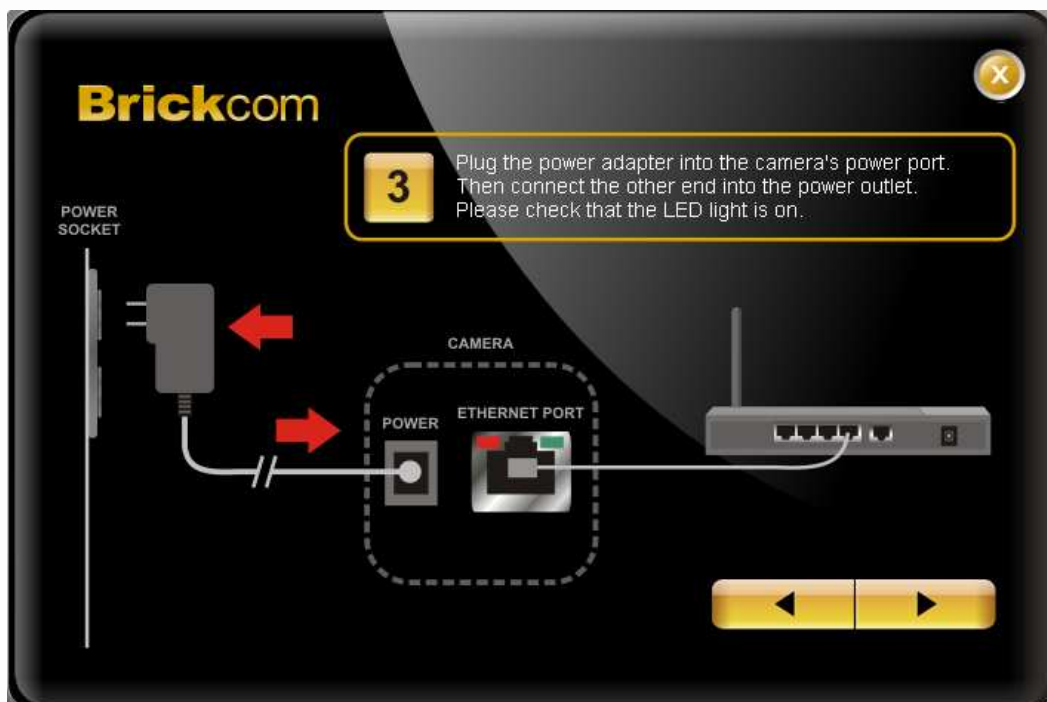

2. The user can either select simple mode or professional mode for the network camera IP setting. If the simple mode is selected, the easy configuration program will set up the connection automatically. If the professional mode is selected, the user will need to configure the IP manually.

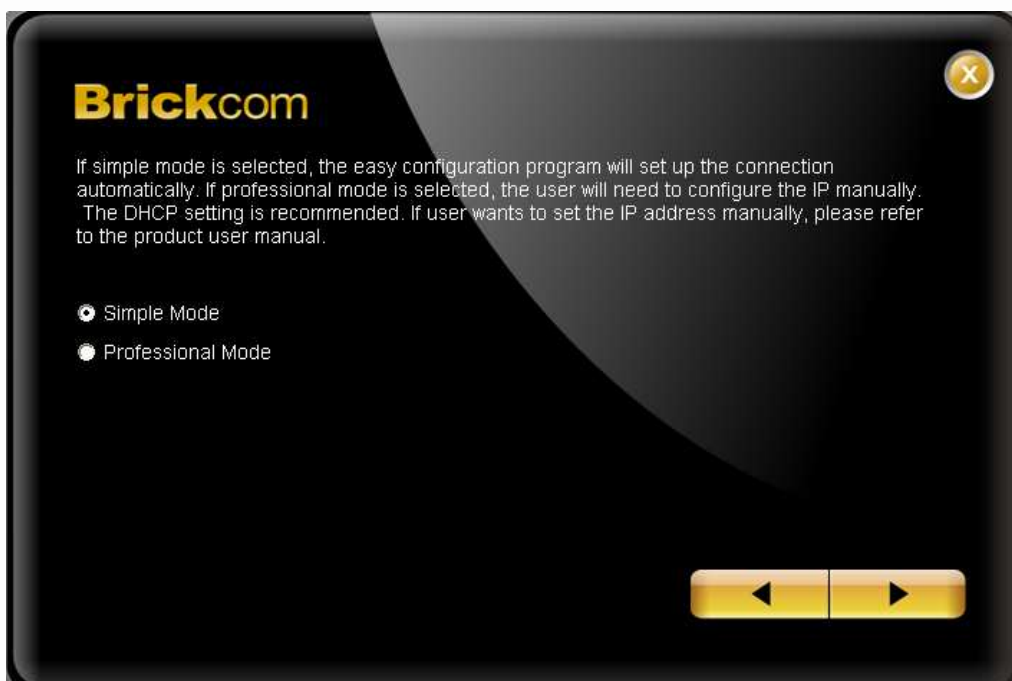

3. There may be many Network Cameras in the local network. The user can differentiate the Network Cameras with the UPnP name. Double click on the desired Network Camera from the survey list to connect.

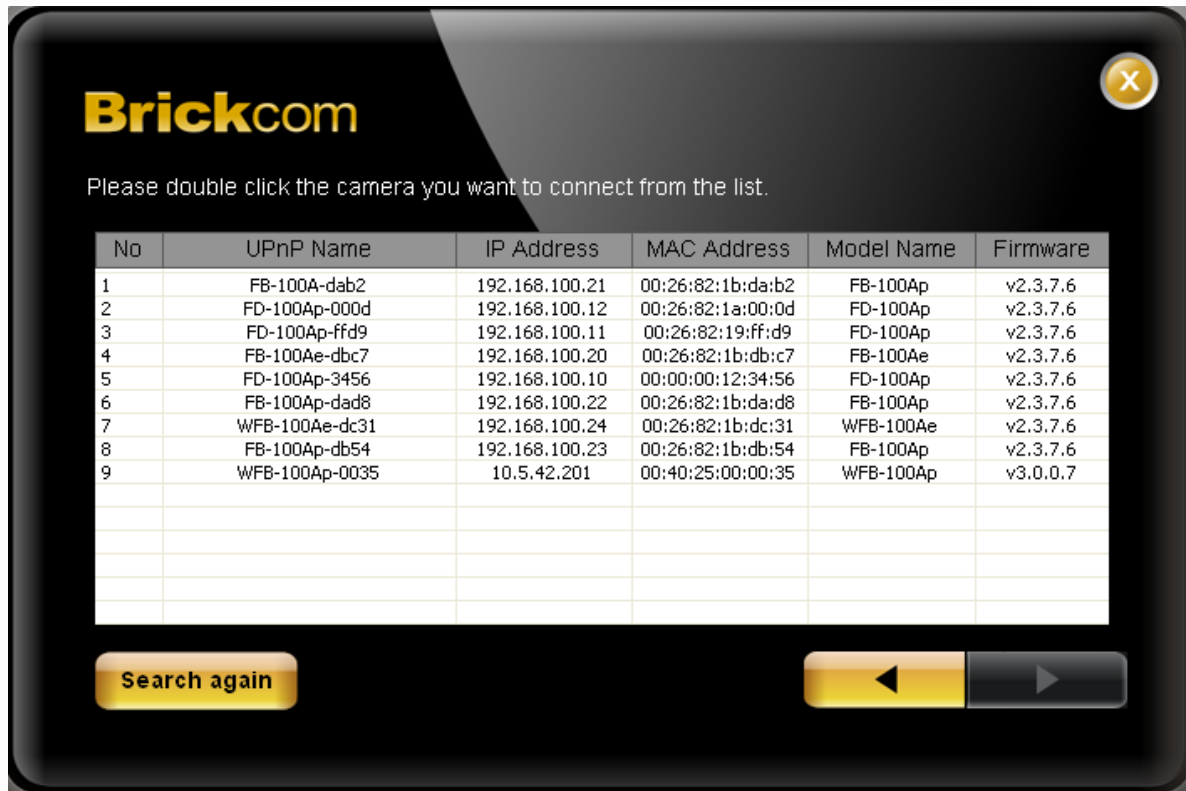

4. Enter the username and password of the camera. For first time use, the default username and password are “**admin/admin.**”



5. For selecting the IP address settings, the user can either select <Settings remains the same>, <Automatically obtain an IP Address (DHCP)> or <Set IP Address configuration manually>. The DHCP setting is recommended. If the user wants to set the IP address manually, please refer to the product user manual.



- a. If <Set IP Address configuration manually> is selected, the following pages will be displayed.



Brickcom

Enter the Static IP Address to configure IP Camera.

IP Address

Subnet Mask

Gateway

DNS1

DNS2



6. If the network camera supports the EasyLink™ function, the following page **will be** displayed. Otherwise, this page **will not** be shown. *Click <Skip> to skip this setting.



EasyLink™ enables network cameras to come with everything necessary to quickly add a surveillance camera to a home or small office network. To view what the camera is seeing, simply log on to mybrickcom.com, choose the device's domain name which was created by the user, and start viewing. There is no need to configure the router to open up ports or remember hard-to-memorize Internet addresses.

As a mybrickcom-enabled device, the camera can be accessed anytime, anywhere by simply logging on to the mybrickcom website and selecting the camera.

- Check the option box to enable EasyLink™. Enter a domain name whose length must be between 5-32 characters.

- For Refresh Time, select a desired amount of time from the drop-down menu to confirm the connection status.
- When finished, click the arrow button to continue.



7. When the IP address settings have been made, the screen will either display a successful or failed connection message. If the connection failed, the user can either try again or quit the installation.

- a. If the DHCP IP address setting was selected, the failure page will be displayed as below:

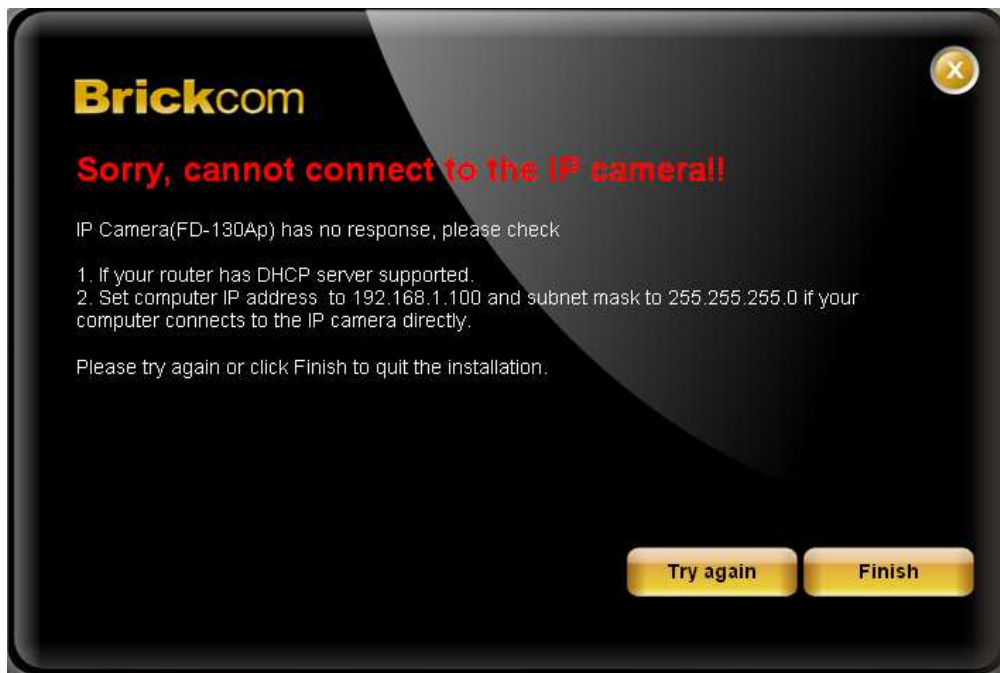

- b. If the Static IP address setting was selected, the failure page will be displayed as below:

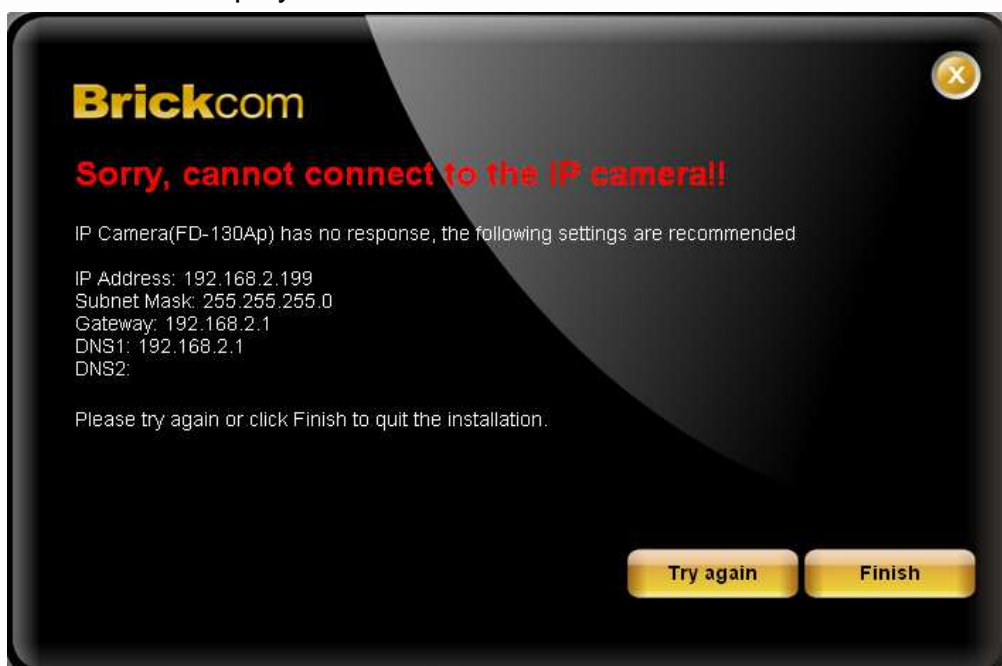

- c. If the connection was successful, the user will see the message:
Congratulations. The installation of the camera is complete.

When this window is displayed, the user can click <X> in the top right corner of the screen to close the installation window, click <PC-NVR> to start the PC-NVR program or, click <Live View> to view the live video from the connected IP camera.

