

Indoor/Outdoor Mounts and Accessories

DIMENSIONS

HQA-BB1

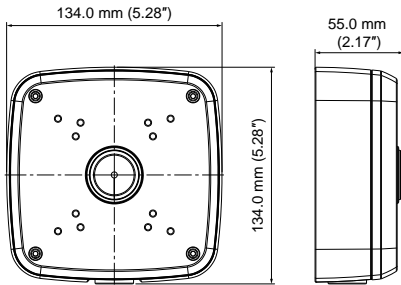

HBS2-BB

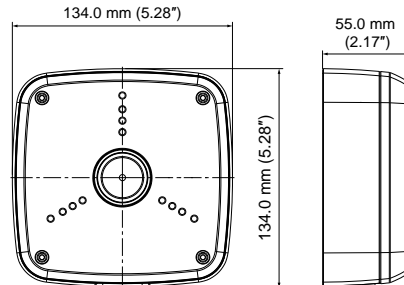

HQA-BB2/HQA-BB2G

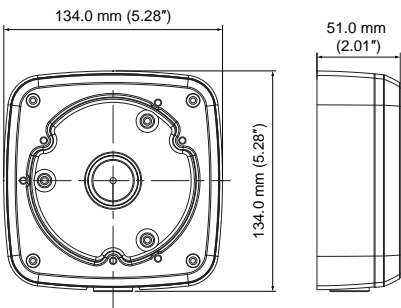

HEJB

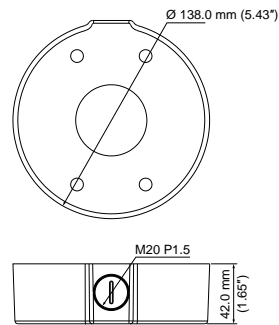

HQA-BB3/HQA-BB3G

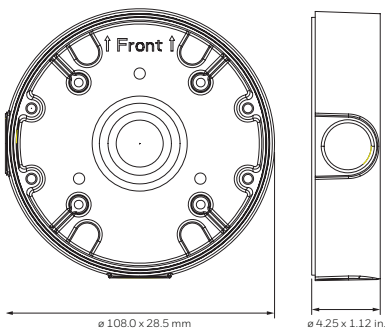

HQA-WK

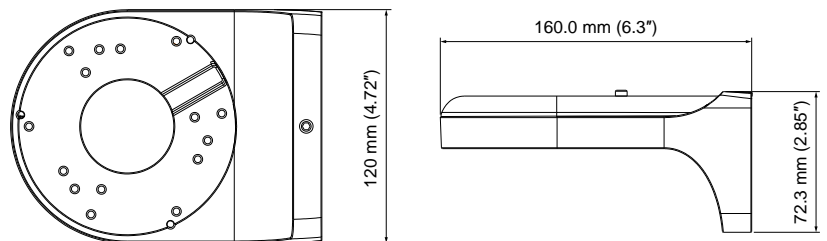

Indoor/Outdoor Mounts and Accessories

DIMENSIONS

HQA-WK2/HQA-WK2G

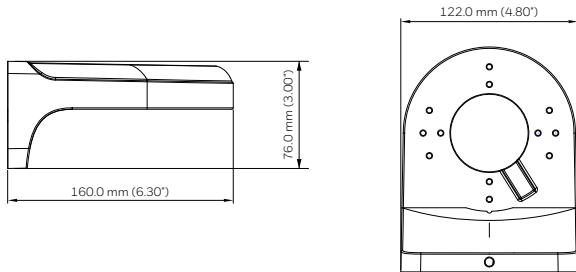

HB34S2-CM

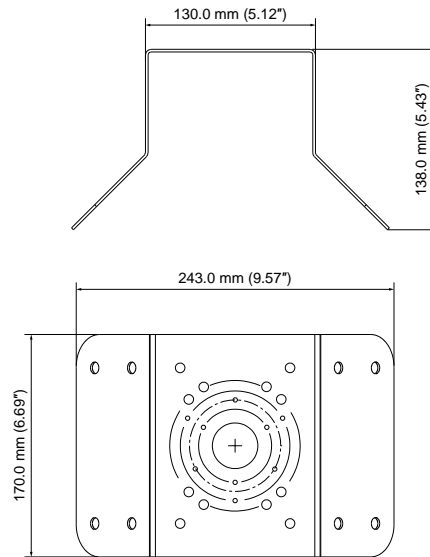

HQA-PM

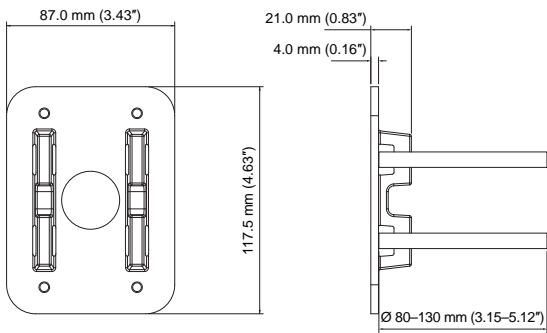

HQA-PM2

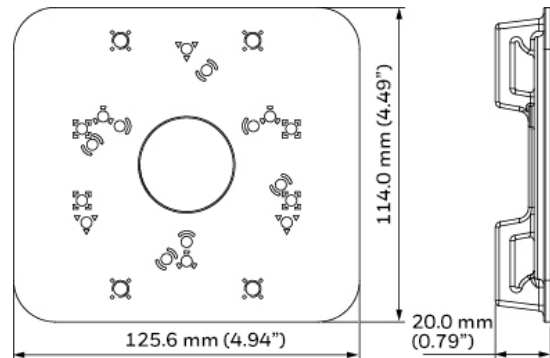

Indoor/Outdoor Mounts and Accessories Specifications

MECHANICAL			
MODEL NO.	UNIT WEIGHT	CONSTRUCTION	DIMENSIONS
HQA-BB1	0.5 kg (1.1 lb)	Die-cast aluminum	134.0 × 134.0 × 55.0 mm (5.28 × 5.28 × 2.17 in.)
HQA-BB2/HQA-BB2G	0.6 kg (1.32 lb)	Die-cast aluminum	134.0 × 134.0 × 51.0 mm (5.28 × 5.28 × 2.01 in.)
HQA-BB3/HQA-BB3G	0.49 kg (1.08 lb)	Die-cast aluminum	∅ 108.0 × 28.5 mm (∅ 4.25 × 1.12 in.)
HBS2-BB	0.5 kg (1.1 lb)	Die-cast aluminum	134.0 × 134.0 × 55.0 mm (5.28 × 5.28 × 2.17 in.)
HEJB	0.38 kg (0.84 lb)	Die-cast aluminum and SECC steel	∅ 138.0 × 42.0 mm (∅ 5.43 × 1.65 in.)
HQA-PM (requires a compatible junction box)	0.2 kg (0.44 lb)	Die-cast aluminum	117.5 × 87.0 × 21.0 mm (4.63 × 3.43 × 0.83 in.)
HQA-PM2 (REQUIRES A COMPATIBLE JUNCTION BOX)	0.27 kg (0.6 lb)	Die-cast aluminum	125.6 × 114.0 × 20.0 mm (4.94 × 4.49 × 0.79 in.)
HB34S2-CM (REQUIRES A COMPATIBLE JUNCTION BOX)	1.7 kg (3.75 lb) SECC steel	243.0 × 170.0 × 138.0 mm (9.57 × 6.69 × 5.43 in.)	9.57 × 6.69 × 5.43 in. (243.0 × 170.0 × 138.0 mm)
HQA-WK	1.0 kg (2.2 lb)	Die-cast aluminum and ABS	120.0 × 72.3 × 160.0 mm (4.72 × 2.85 × 6.3 in.)
HQA-WK2/HQA-WK2G	0.16 kg (0.35 lb)	Die-cast aluminum	160.0 × 122.0 × 76.0 mm (6.30 × 4.80 × 3.00 in.)

COMPATIBLE HQA AND IP CAMERAS

MOUNTS	COMPATIBLE PERFORMANCE HQA CAMERAS	MOUNTS	COMPATIBLE PERFORMANCE IP CAMERAS
HQA-BB1	HB74HD4	HQA-BB1	HBW2PR1, HBW4PR1, HBD8PR1
HQA-BB2/G	HD72HD4, HD274HD4	HQA-BB2/G	H4D3PRV2, H4D2PRV3, H4W2PRV2, H4W4PRV2, H4W4PRV3, HEW2PR2, HEW4PR2, H4D8PR1, HFD5PR1
HQA-BB3/G	HD30HD4	HQA-BB3/G	H2W2PRV3, H2W4PRV3, HEW2PR1, HEW2PRW1, HEW3PR3, HEW4PRW3, HED8PR1
HBS2-BB	HB276HD4	HBS2-BB	HED1PR3, HED3PR3, HBD1PR1, HBD3PR1, HBD3PR2, HBW2PR2, HBW4PR2
HQA-PM*	All HQA cameras (with a compatible junction box)	HEJB	HED1PR3, HED3PR3, HBD1PR1, HBD3PR1
HQA-PM2*	All HQA cameras (with a compatible junction box)	HQA-PM*	H4W2PRV2, H4W4PRV2, H4W4PRV3, HBW2PR1, HBW4PR1, HBW2PR2, HBW4PR2, HEW2PR2, HEW4PR2 (with a compatible junction box)
HB34S2-CM*	All HQA cameras (with a compatible junction box)	HQA-PM2*	HED8PR1, HBD8PR1, H4D8PR1, HFD5PR1 (with a compatible junction box)
HQA-WK	HD274HD4, HD72HD4	HB34S2-CM*	H2W2PRV3, H2W4PRV3, H4W2PRV2, H4W4PRV2, H4W4PRV3, HBW2PR1, HBW4PR1, HBW2PR2, HBW4PR2, HEW2PR1, HEW2PRW1, HEW2PR2, HEW4PR2, HEW4PR3, HEW4PRW3, HED8PR1, HBD8PR1, H4D8PR1 (with a compatible junction box)
		HQA-WK	HED1PR3, HED3PR3, H4D3PRV2, H4D3PRV3, H4W2PRV2, H4W4PRV2, H4W4PRV3, HEW2PR2, HEW4PR2, H4D8PR1, HFD5PR1
		HQA-WK2/G	H2W2PRV3, H2W4PRV3, HEW2PR1, HEW2PRW1, HEW4PR3, HEW4PRW3, HED8PR1

ORDERING

HQA-BB1	Junction Box, Off-White	HQA-PM*	Pole Mount Adapter, Off-White	* A compatible junction box is required when installing to either the HQA-PM pole mount, the HQA-PM2 pole mount or the HB34S2-CM corner mount.
HQA-BB2	Junction Box, Off-White	HQA-PM2*	Pole Mount Adapter, Off-White	
HQA-BB2G	Junction Box, Grey	HB34S2-CM*	Corner Mount Adapter, Off-White	
HQA-BB3	Junction Box, Off-White	HQA-WK	Wall Mount, Off-White	
HQA-BB3G	Junction Box, Grey	HQA-WK2	Wall Mount, Off-White	
HBS2-BB	Junction Box, Off-White	HQA-WK2G	Wall Mount, Grey	
HEJB	Junction Box, Off-White			

For more information

www.honeywell.com/security/uk

Honeywell Security and Fire

Aston Fields Road
Whitehouse Industrial Estate
Runcorn
Cheshire WA7 3DL
Tel: 08448 000 235
www.honeywell.com

Honeywell reserves the right, without notification, to make changes in product design or specifications.

HSFV-PerfIPHQA_IOMA-01-UK(0617)DS-R
© 2017 Honeywell International Inc.

Honeywell