

30 SERIES CAMERAS MOUNTS AND ACCESSORIES

Honeywell's 30 Series mounts and accessories provide a wide range of installation options for the Honeywell 30 Series IP cameras, including junction box, mounting adapter, pendant pipe, wall mount bracket, pole mount adapter, corner mount adapter, etc.

The mounts provide easy cable routing with no exposed wiring, and the cameras can be installed, adjusted, and tested without repositioning the housing. All of the mounts and accessories are suitable for indoor or outdoor use.

The junction box, pendant mounting cap, pendant mounting pipe, wall mounting bracket and pole mounting adapter are constructed of die-casting aluminum. The corner mounting adapter is made of SECC steel. All of the mounts and accessories are powder coated to match the finish of the camera.

MARKET OPPORTUNITIES

Honeywell's 30 Series mounts and accessories provide excellent value at an attractive price, featuring simple, clean lines, and rugged construction for a wide range of mounting options.



HA30JCB01
Junction
Box



HA30PMC01
Pendant Mounting
Cap



HA30PMC02
Pendant Mounting
Cap



HA30PMC03
Pendant Mounting
Cap



HA30PME01
Pendant Mounting
Pipe



HA30PME02
Pendant Mounting
Pipe



HA30PMB01
Pendant Mounting
Base



HA30WLM01
Wall Mounting
Bracket



HA30WLM03
Wall Mounting
Bracket



HA30PLM01
Pole Mounting
Adapter



HA30CNM01
Corner Mounting
Adapter



30 SERIES MOUNTS AND ACCESSORIES

DIMENSIONS

HA30JCB01

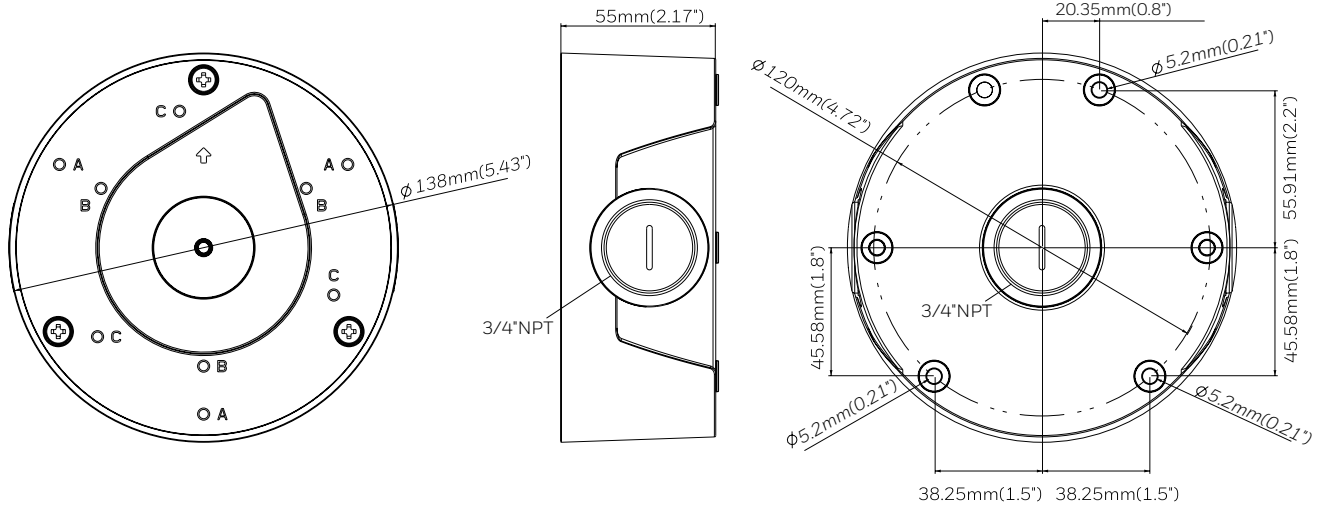

HA30PMC01

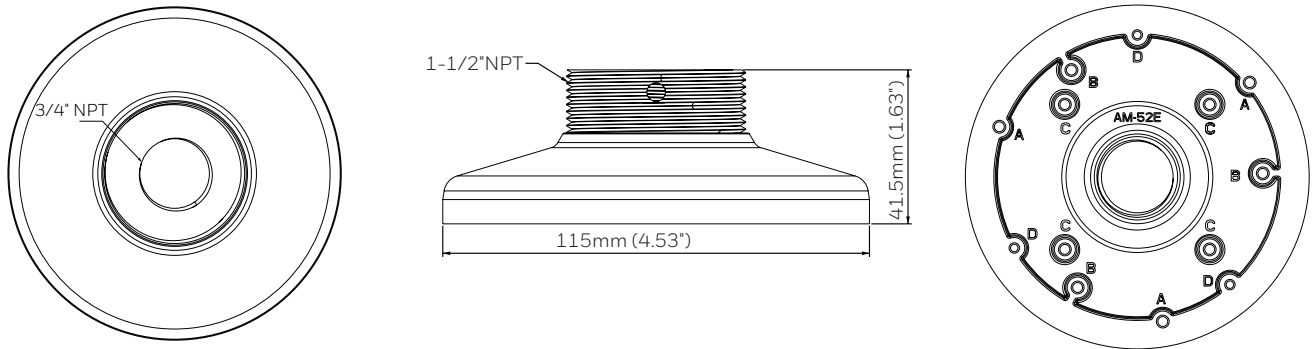

HA30PMC02

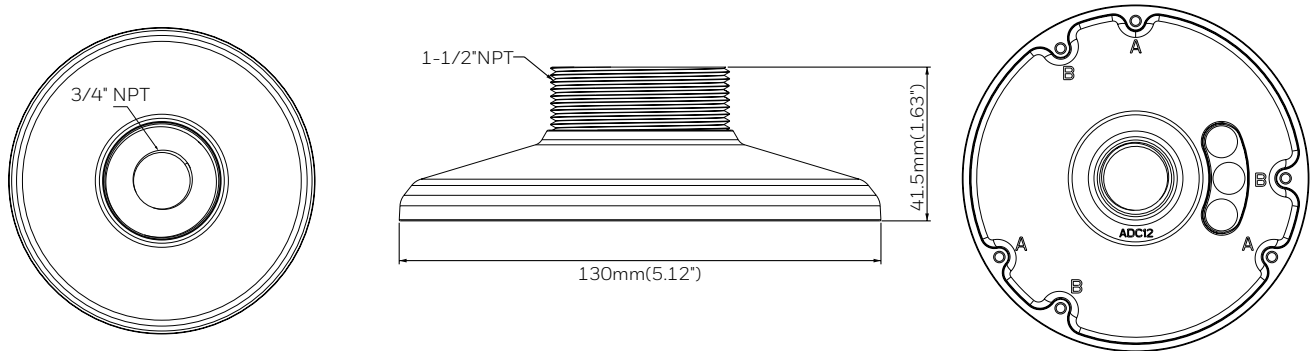

30 SERIES MOUNTS AND ACCESSORIES

DIMENSIONS

HA30PMC03

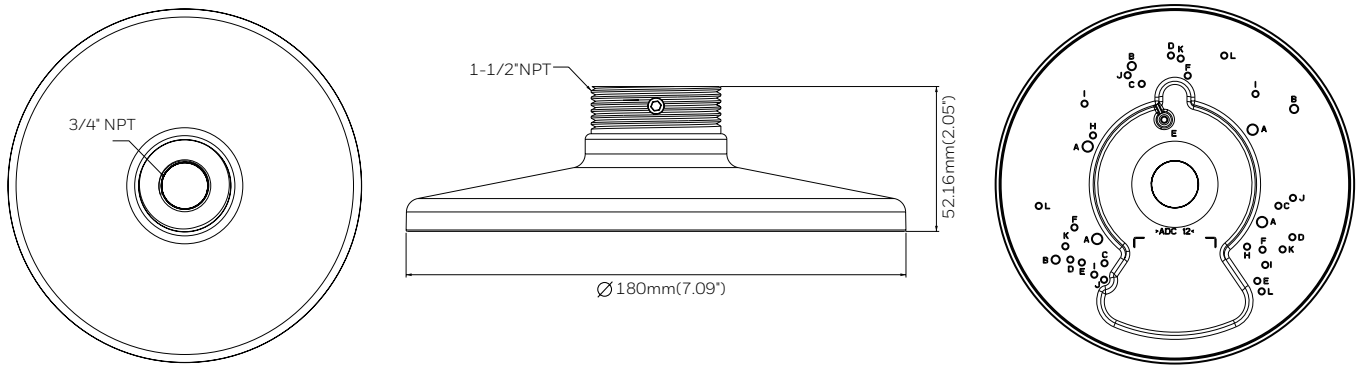

HA30PME01

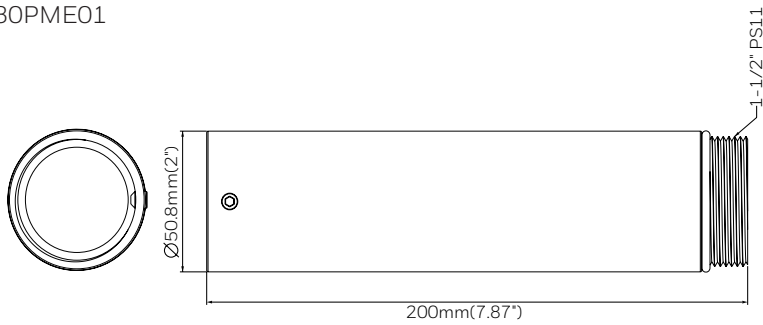

HA30PME02

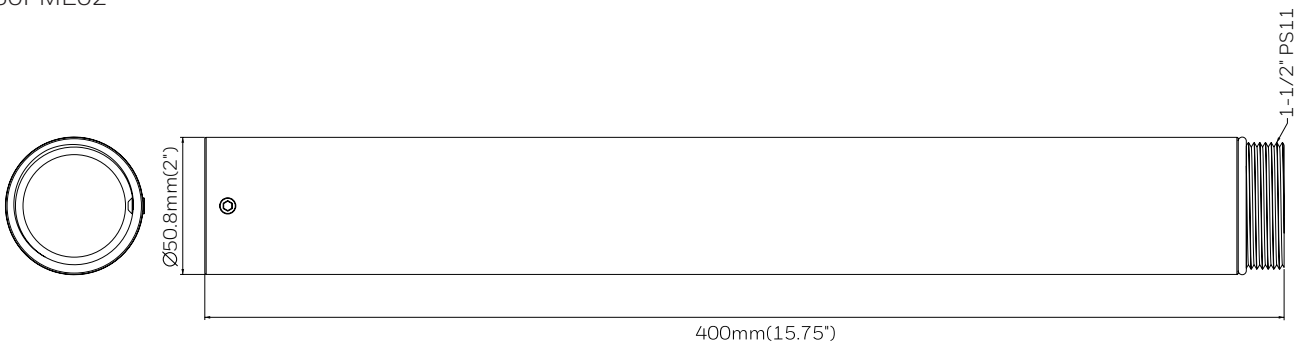

30 SERIES MOUNTS AND ACCESSORIES

DIMENSIONS

HA30PMB01

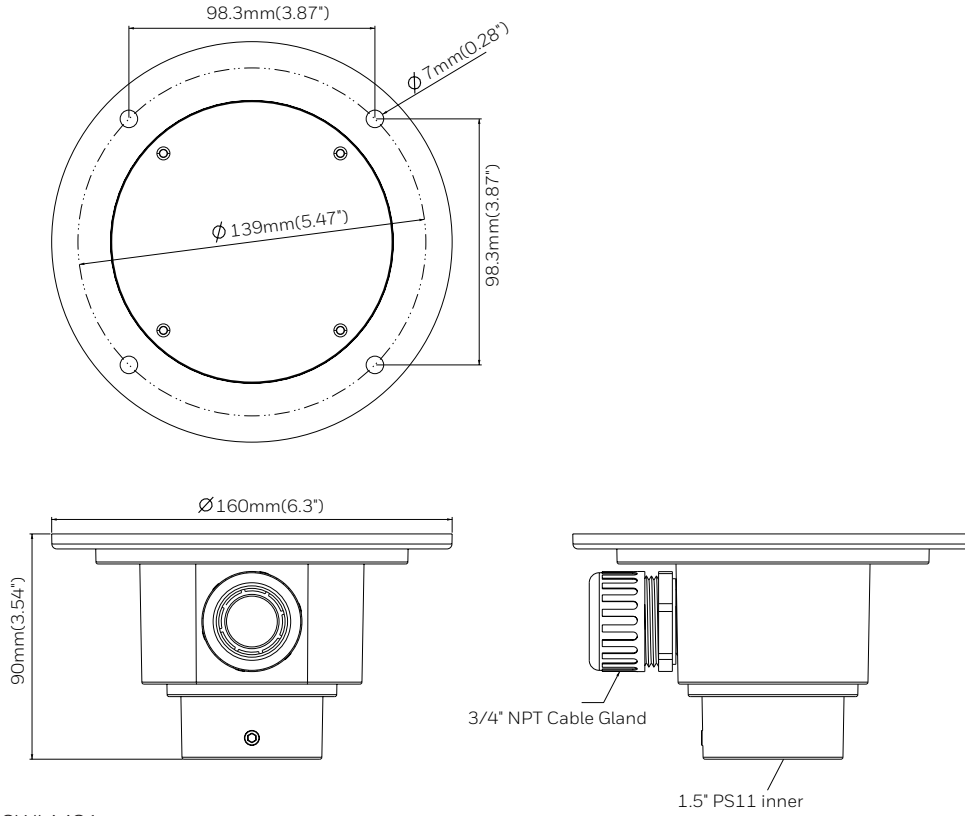

HA30WLM01

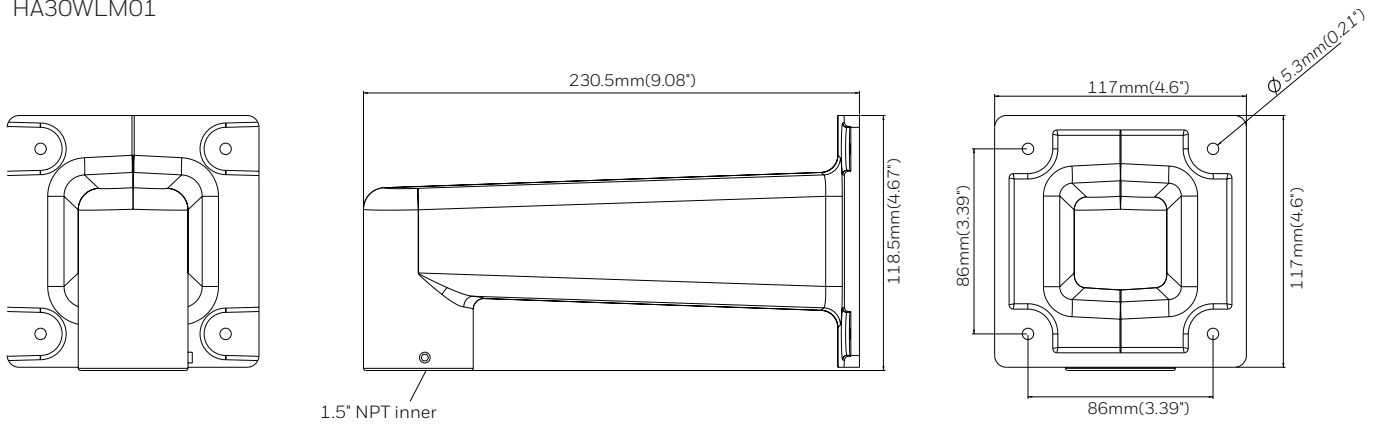

HA30WLM03

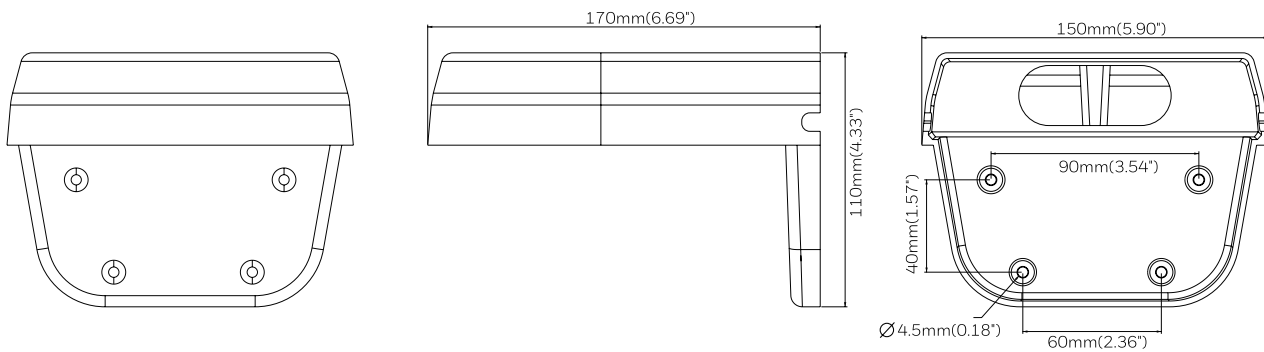

30 SERIES MOUNTS AND ACCESSORIES

DIMENSIONS

HA30PLM01

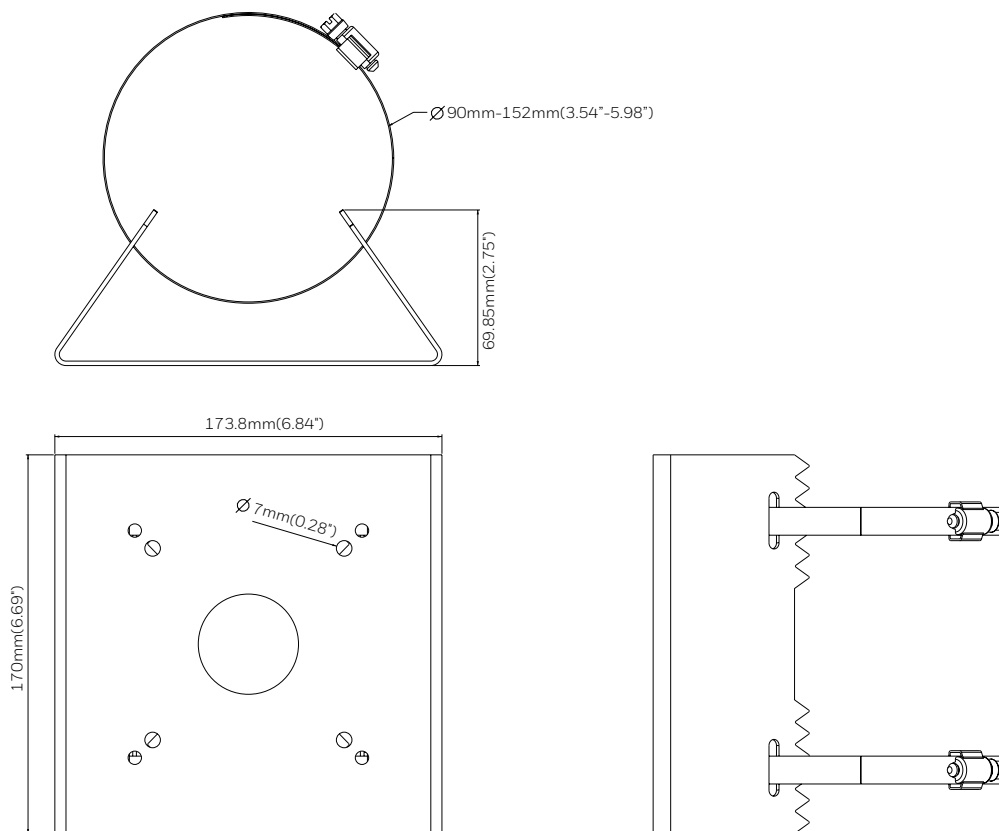



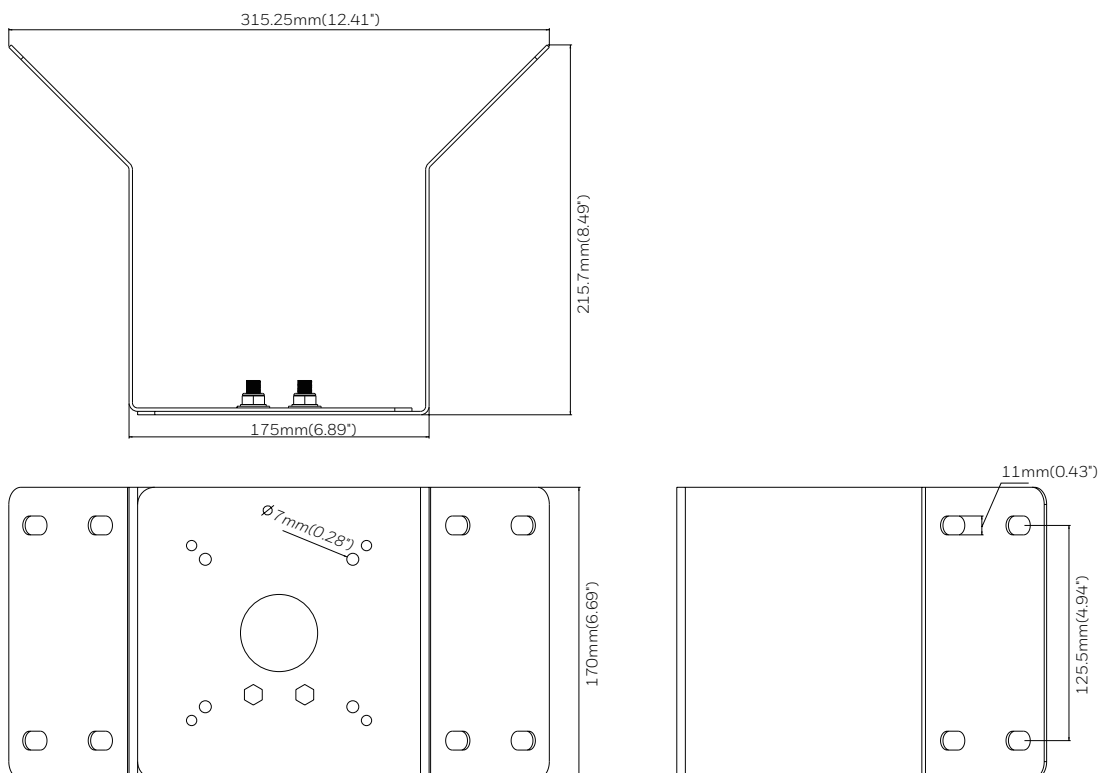



















HA30CNM01



30 SERIES MOUNTS AND ACCESSORIES

COMPATIBLE CAMERAS

MODEL	HC30W42R3 HC30W45R3	HC30W45R2	HC30WB2R1 HC30WB5R1 HC30WB5R2	HC30WE2R3 HC30WE5R3	HC30WE5R2	HC30WF5R1
HA30JCB01 						
HA30PMC01 						
HA30PMC02 						
HA30PMC03 						
HA30PMB01 	+HA30PME01 +HA30PMC01	+HA30PME01 +HA30PMC02		+HA30PME01 +HA30PMC01	+HA30PME01 +HA30PMC01	+HA30PME01 +HA30PMC03
HA30PME01 						
	or +HA30PME02 +HA30PMC01	or +HA30PME02 +HA30PMC02		or +HA30PME02 +HA30PMC01	or +HA30PME02 +HA30PMC01	or +HA30PME02 +HA30PMC03
HA30PME02 						

30 SERIES MOUNTS AND ACCESSORIES

COMPATIBLE CAMERAS

MODEL	HC30W42R3 HC30W45R3	HC30W45R2	HC30WB2R1 HC30WB5R1 HC30WB5R2	HC30WE2R3 HC30WE5R3	HC30WE5R2	HC30WF5R1
HA30WLM01 	+HA30PMC01 	+HA30PMC02 		+HA30PMC01 	+HA30PMC01 	+HA30PMC03 
HA30WLM03 						
HA30PLM01 	+HA30WLM01 +HA30PMC01 	+HA30WLM01 +HA30PMC02 		+HA30WLM01 +HA30PMC01 	+HA30WLM01 +HA30PMC01 	+HA30JCB03 +HA30PMC03 
HA30CNM01 	+HA30WLM01 +HA30PMC01 	+HA30WLM01 +HA30PMC02 		+HA30WLM01 +HA30PMC01 	+HA30WLM01 +HA30PMC01 	+HA30JCB03 +HA30PMC03 

30 SERIES MOUNTS AND ACCESSORIES

SPECIFICATIONS

MODEL	UNIT WEIGHT	CONSTRUCTION	DIMENSIONS
HA30JCB01	1.92 lb (0.87 kg)	Die-casting aluminum	Ø 5.43 x 2.17 in. (Ø 138 x 55 mm)
HA30PMC01	0.54 lb (0.24 kg)	Die-casting aluminum	Ø 4.53 x 1.63 in. (Ø 115 x 41.5 mm)
HA30PMC02	0.42 lb (0.19 kg)	Die-casting aluminum	Ø 5.12 x 1.63 in. (Ø 130 x 41.5 mm)
HA30PMC03	1.70 lb (0.77 kg)	Die-casting aluminum	Ø 7.09 x 2.05 in. (Ø 180 x 52.16 mm)
HA30PME01	0.95 lb (0.43 kg)	Aluminum	Ø 2 x 7.87 in. (Ø 50.8 x 200 mm)
HA30PME02	1.98 lb (0.9 kg)	Aluminum	Ø 2 x 15.75 in. (Ø 50.8 x 400 mm)
HA30PMB01	1.63 lb (0.74 kg)	Die-casting aluminum and PC Gland	Ø 6.3 x 3.54 in. (Ø 160 x 90 mm)
HA30WLM01	1.46 lb (0.66 kg)	Die-casting aluminum	9.08 x 4.6 x 4.67 in. (230.5 x 117 x 118.5 mm)
HA30WLM03	1.28 lb (0.58 kg)	Die-casting aluminum and SECC steel	6.69 x 5.9 x 4.33 in. (170 x 150 x 110 mm)
HA30PLM01	2.65 lb (1.2 kg)	SECC Steel and SUS304	6.84 x 6.69 x 2.75 in. (173.8 x 170 x 69.85 mm)
HA30CNM01	4.85 lb (2.2 kg)	SECC Steel	12.41 x 8.49 x 6.69 in. (315.25 x 215.7 x 170 mm)

ORDERING

MODEL	DESCRIPTION	MODEL	DESCRIPTION
HA30JCB01	30 Series Junction Box, Round	HA30PMB01	30 Series Pendant Mounting Base
HA30PMC01	30 Series Pendant Mounting Cap, 3/4" NPT Female Connector	HA30WLM01	30 Series Wall Mounting Bracket
HA30PMC02	30 Series Pendant Mounting Cap, 3/4" NPT Female Connector	HA30WLM03	30 Series Wall Mounting Bracket
HA30PMC03	30 Series Pendant Mounting Cap, 3/4" NPT Female Connector	HA30PLM01	30 Series Pole Mounting Adapter
HA30PME01	30 Series Pendant Mounting Pipe, 20 cm	HA30CNM01	30 Series Corner Mounting Adapter
HA30PME02	30 Series Pendant Mounting Pipe, 40 cm		

For more information

www.security.honeywell.com/uk
www.security.honeywell.com/me

Honeywell Commercial Security

Honeywell Security Office -
Emaar Business Park,
Sheikh Zayed Road
Building No. 2, 2nd floor, 201
Post Office Box 232362
Dubai, United Arab Emirates
Tel: +971 44541704

Aston Fields Road
Whitehouse Industrial Estate
Runcorn, Cheshire, WA7 3DL
United Kingdom
Tel: +44 (0)8448 000 235
www.honeywell.com

Honeywell reserves the right, without notification, to make changes in product design or specifications.

HSV-30ACC-01-UK(0620)DS-Z
© 2020 Honeywell International Inc.

Honeywell