

# C11-UM, CM1751, and TB1751 Series Mounts

## WALL, CEILING, PEDESTAL, T-BAR, GANG BOX MOUNT FOR CAMERAS

### Product Features

- Low Cost Camera Mount
- Contemporary Design
- Adjustable Swivel Head
- Supports up to 3.2 kg (7 lb)
- Wall, Ceiling, Pedestal, False T-Rail, or Gang Box Mounting
- Two Length Configurations
- Available in Gray

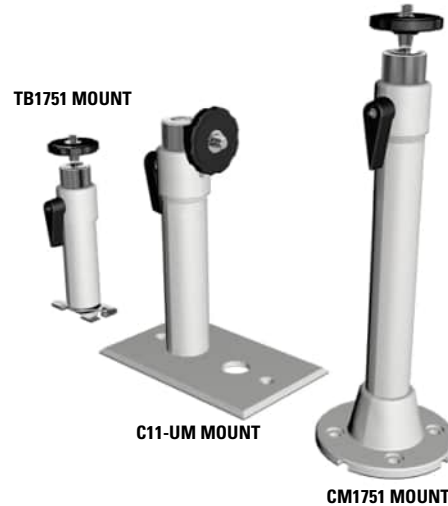

The **C11-UM**, **CM1751**, and **TB1751** are universal camera mounts designed for use with cameras weighing up to 3.2 kg (7 lb). All mounts feature an easily adjustable swivel head for camera positioning.

The **C11-UM** mount is designed for mounting to a single gang box but can also be used for wall or ceiling mounting.

The **CM1751** mount is primarily designed for ceiling or pedestal mounting, but can also be used for wall mounting.

The **TB1751** mount is specifically engineered for mounting on a T-rail in false ceiling applications.

Each mount can be configured to two different lengths with the included extension tube.



# TECHNICAL SPECIFICATIONS

## MODEL

C11-UM	Universal gang box, wall, or ceiling mount with adjustable swivel head, gray
CM1751	Universal wall, ceiling, or pedestal camera mount with adjustable swivel head, gray
TB1751	Universal T-rail camera mount with adjustable swivel head for use in false ceilings, gray

## MECHANICAL

Pan Adjustment	360°
Tilt Adjustment	90° maximum
Camera Mounting	1/4-20 threaded stud with nut
Locking Method	Cam action lever arm

## GENERAL

Construction	Aluminum
Finish	Gray polyester powder coat
Maximum Load	7 lb (3.2 kg)
Unit Weight	
C11-UM	0.22 kg (0.50 lb)
CM1751	0.22 kg (0.50 lb)
TB1751	0.17 kg (0.38 lb)
Shipping Weight	
C11-UM	0.90 kg (2.0 lb)
CM1751	0.90 kg (2.0 lb)
TB1751	0.45 kg (1.0 lb)

### C11-UM MOUNT

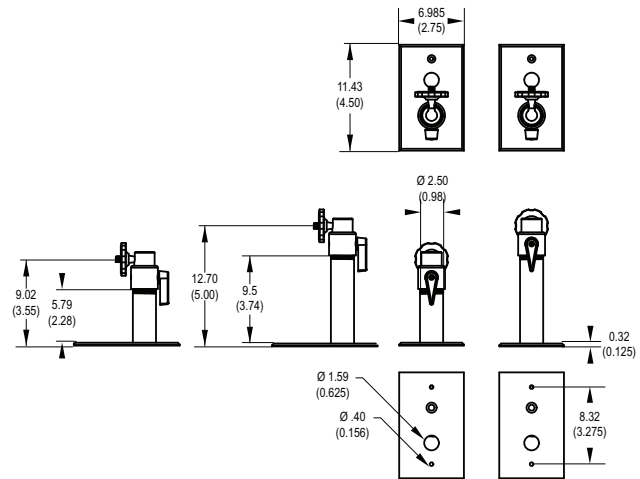

### CM1751 MOUNT

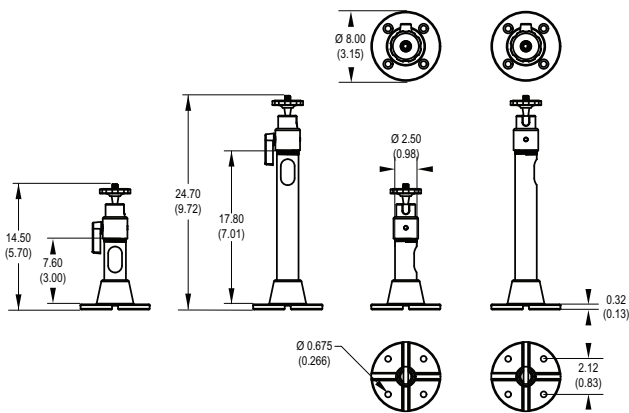

### TB1751 MOUNT

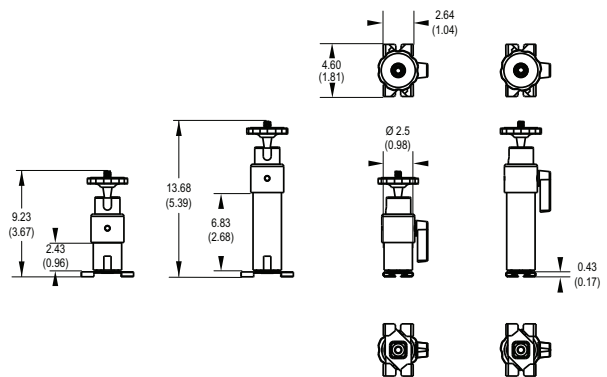

**⚠ WARNING: Cancer and Reproductive Harm - www.P65Warnings.ca.gov**  
**⚠ ADVERTENCIA: Cáncer y Daño Reproductivo - www.P65Warnings.ca.gov**  
**⚠ AVERTISSEMENT: Cancer et Troubles de la reproduction - www.P65Warnings.ca.gov**

**Pelco, Inc.**  
 625 W. Alluvial, Fresno, California 93711 United States  
**USA & Canada** Tel (800) 289-9100 Fax (800) 289-9150  
**International** Tel +1 (559) 292-1981 Fax +1 (559) 348-1120  
[www.pelco.com](http://www.pelco.com)

Pelco, the Pelco logo, and other trademarks associated with Pelco products referred to in this publication are trademarks of Pelco, Inc. or its affiliates. ONVIF and the ONVIF logo are trademarks of ONVIF Inc. All other product names and services are the property of their respective companies. Product specifications and availability are subject to change without notice.  
 ©Copyright 2018, Pelco, Inc. All rights reserved.