

Vi00103

NetMux™ Ethernet and PoE Port Multiplexer

Features

- Connects two IP/PoE devices to a PoE switch using a single Cat5/6 cable
- Provides up to 37W to each of 2 devices
- Reduces installation costs and time
- Indicates PoE presence at Camera side (TX module)
- Compatible with IEEE 802.3af and IEEE 802.3at
- No power source required
- Low cost and easy to use



Applications

- Adding a new IP camera to an existing installation without extra wiring
- Home security and communication applications
- Cost-effective solution for powering two IP devices using a single cable

The NetMux™ Vi00103 port multiplexer enables connecting two IP/POE devices using a single Cat5/6 cable. It includes a port Combiner and a port Splitter. The Vi00103RX combines two IP/PoE signal and transmits them through only one Cat5/6 cable. It has two built-in 10 inch Cat 5 pigtail cables to connect to the PoE switch. The Vi00103TX separates the combined signals and connects them to two ports of the PoE switch. It has two integrated LEDs to provide indication of PoE status for each port.

The Vi00103 can handle PoE inputs of up to 37W for each connected device. The NetMux™'s innovative design is compact and easy to use. It is compatible with IEEE 802.af, IEEE 802.at and most non-standards POE systems up to 37W for 10/100 BASE-T environments.

NetMux™ is a perfect solution for reducing installation costs or adding PoE cameras or other IP/PoE devices to an existing installation.



The Smart Choice for Transmission Solutions



www.vigitron.com

Technical Specification*

Electrical

Ethernet Interface	10BASE-T and 100BASE-T
Power Source	No external power source needed
Connections	Vi00103RX: 2 x Male RJ45, 1 x Female RJ45 Vi00103TX: 3 x Female RJ45
Status LEDES	Vi00103RX: N/A Vi00103TX: Port 1 PoE Output: Green LED Port 2 PoE Output: Green LED
PoE Compatibility	IEEE802.3af/at maximum 37W per port

Regulatory

Safety	CE, FCC
Environmental	RoHS, WEEE

Environmental

Humidity	0 to 95%, non-condensing
Temperature	Operating: -40°C to +75° C Storage: -40°C to +80°C

Mechanical

Dimensions	Vi00103RX: 0.8x0.84x1.90 in, 2.03x2.13x4.83 cm (HxWxL) w/ two 10 inches (25 cm) pigtail Cables Vi00103TX: 0.83x1.39x1.44 in, 2.11x3.53x3.66 cm (HxWxL)
Weight	Vi00103RX: 0.068 lb (31 g) Vi00103TX: 0.035 lb (16 g)
Housing	ABS plastic, UL rating of 94V-0

*Specifications subject to change without notice.

Ordering Information

Part No.	Description
Vi00103	Ethernet and PoE Port Multiplexer



Mechanical Drawings

Vi00103RX:

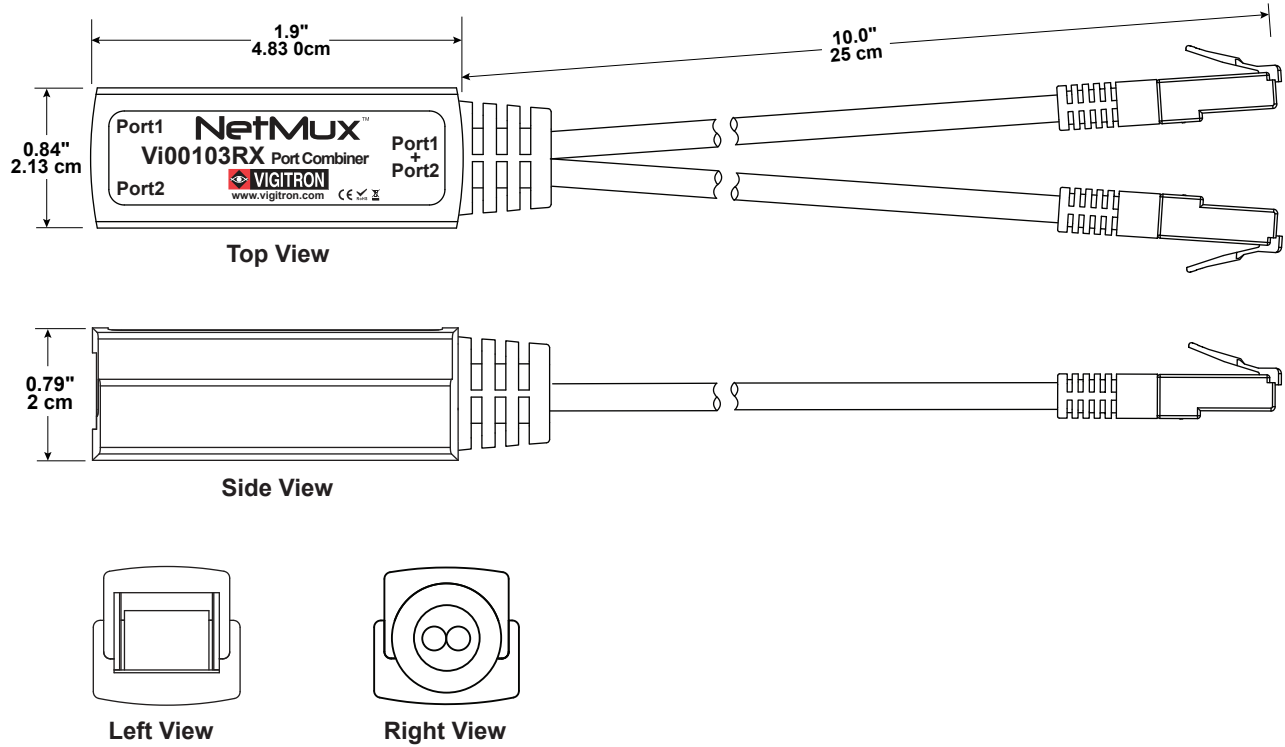

Vi00103TX:

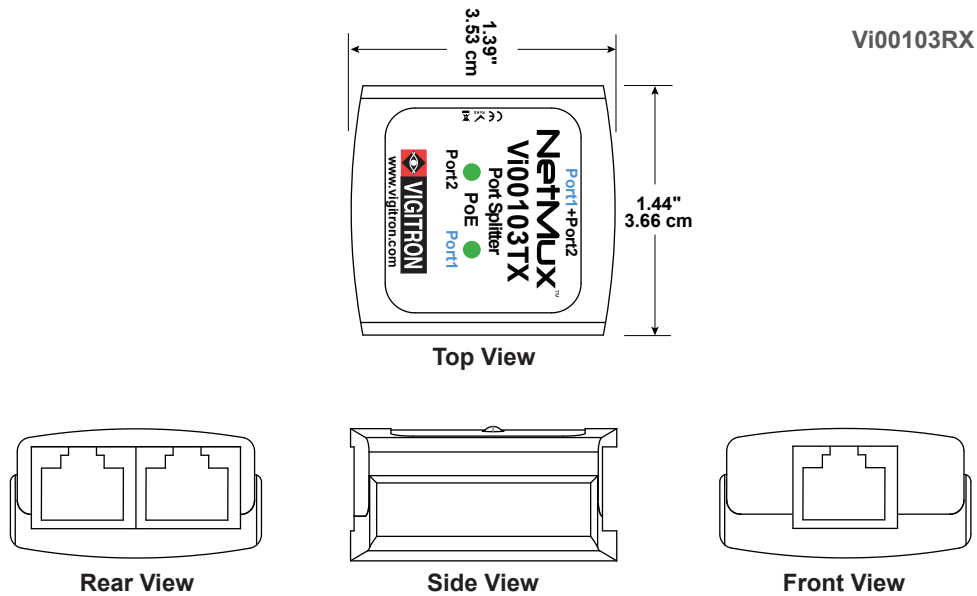

Application Drawings

— Cat 5/6

Connecting Multiple PoE Cameras at Standard UTP Distances

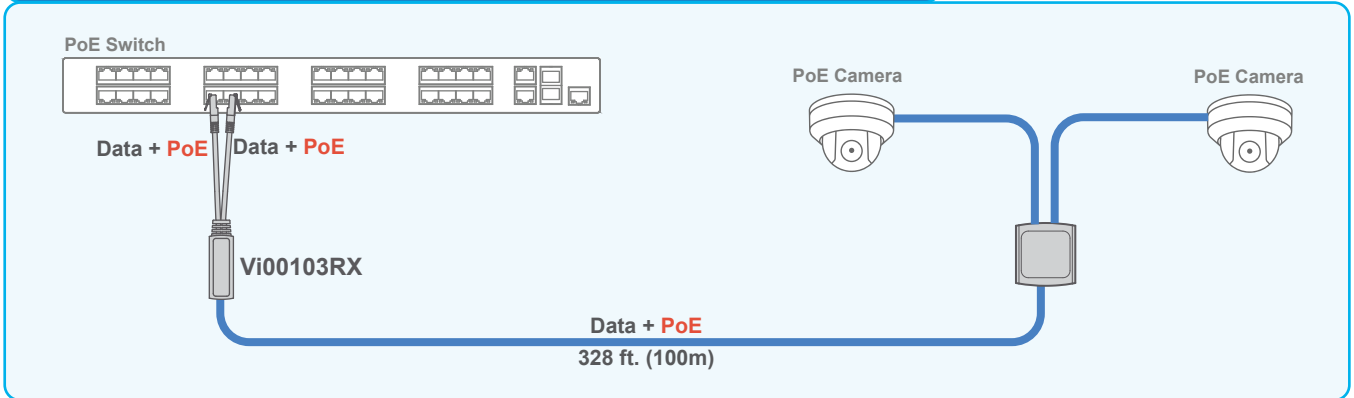

The NetMux™ Vi00103 can connect two cameras at standard UTP distances over a single cable.

Connecting Multiple PoE Cameras at Extended UTP Distances

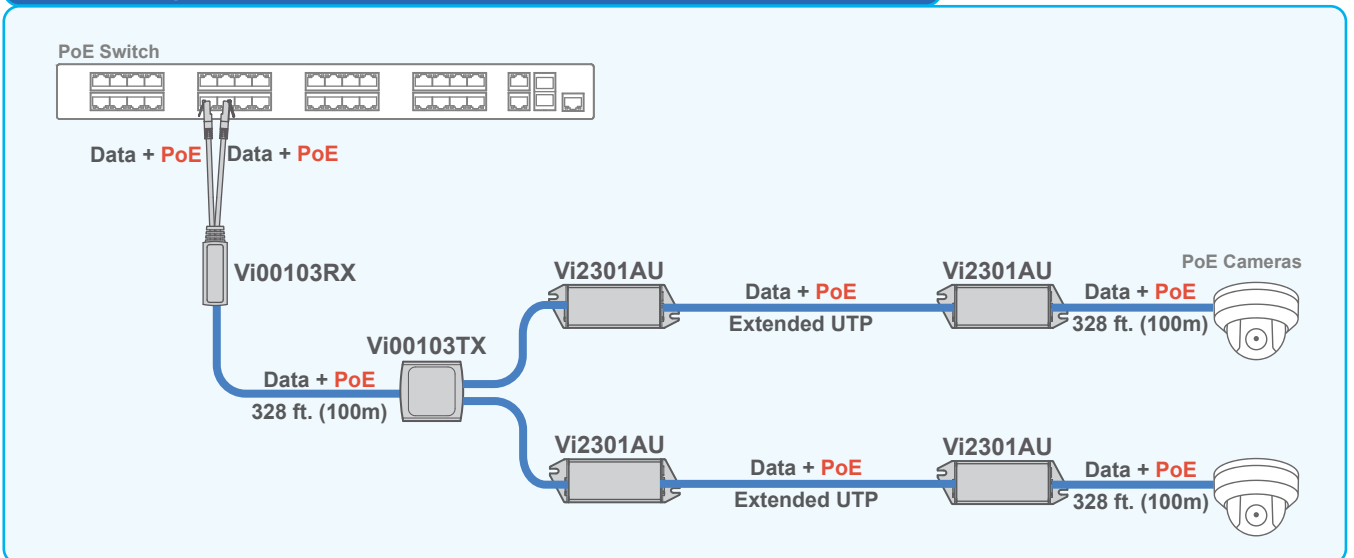

The NetMux™ Vi00103 along with Vi2300 series can connect two cameras at extended UTP distances.