



# AXIS A1810-B Network Door Controller

Compact, cost-effective controller for up to 8 doors

This multi-door controller offers complete control for up to eight doors including support for up to 16 OSDP readers and 16 locks. Ideal for new and retrofit centralized installations with Axis or third-party cabinets. It offers a smaller footprint design than most door controllers on the market. Built-in lock power management simplifies installation. With support for OSDP readers and an optional accessory for Wiegand readers, this scalable door controller is optimized for both small and large installations. It can be used with AXIS Camera Station Secure Entry or partner solutions to provide an all-in-one video and access control management system.

- > [Centralized control simplifies installation](#)
- > [Full control for up to eight doors](#)
- > [Onboard support for 16 OSDP readers and 16 locks](#)
- > [OSDP Verified for secure reader communication](#)
- > [Built-in cybersecurity features](#)

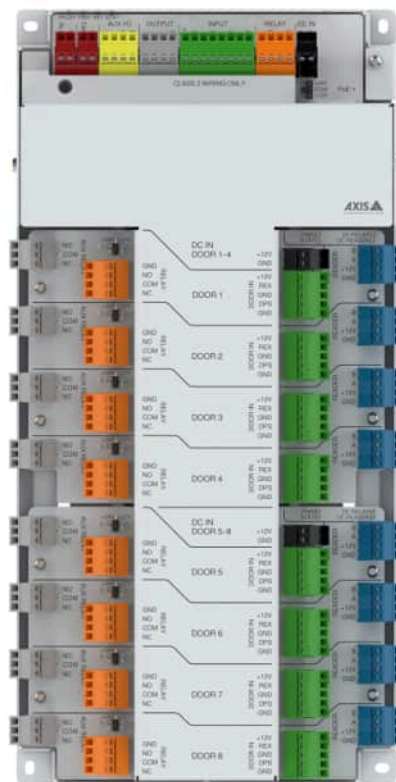

# AXIS A1810-B Network Door Controller

<b>Door controller</b>	
<b>Readers</b>	Up to 16 OSDP and Wiegand <sup>a</sup> readers (multidrop <sup>9</sup> ) per controller OSDP Secure Channel supported, OSDP verified
<b>Doors</b>	8 doors, two relays supporting double locks per door Support for integrating up to 16x ASSA ABLOY Aperio <sup>®</sup> wireless lock <sup>9</sup>
<b>Credentials</b>	Qualified for up to 250 000 credentials stored locally
<b>Event buffer</b>	Qualified for up to 250 000 events stored locally
<b>Power</b>	
<b>Input</b>	Power over Ethernet (PoE) IEEE 802.3at, Type 2 Class 4 or DC IN: 12 V DC, max 36 W DC IN DOOR 1–4: 12 V DC, max 100 W (required) DC IN DOOR 5–8: 12 V DC, max 100 W (required)
<b>I/O interface</b>	
<b>Reader</b>	DOOR 1–4 power out <sup>b</sup> : 4x 12 V DC output, combined total of max 2 A DOOR 5–8 power out <sup>b</sup> : 4x 12 V DC output, combined total of max 2 A Data: 8x OSDP/RS485 half duplex, multidrop <sup>9</sup>
<b>Door input</b>	DOOR 1–4 power out <sup>b</sup> : 4x 12 V DC output, combined total of max 400 mA DOOR 5–8 power out <sup>b</sup> : 4x 12 V DC output, combined total of max 400 mA DOOR 1–4 input: 4x REX and 4x door position sensor, digital input 0 to max 30 V DC, possible to supervise between 0–12 V DC (4 states) DOOR 5–8 input: 4x REX and 4x door position sensor, digital input 0 to max 30 V DC, possible to supervise between 0–12 V DC (4 states)
<b>Relays</b>	RELAY: 1x form C relay, NO/NC Dry: max 2 A at 30 V DC Wet: DC output <sup>b</sup> : 12/24 V DC, jumper configurable With PoE: max 150 mA at 12 V DC, max 50 mA at 24 V DC, max 1.8 W With PoE+: max 920 mA at 12 V DC, max 420 mA at 24 V DC, max 11.04 W With DC in: max 1900 mA at 12 V DC, max 1000 mA at 24 V DC, max 24 W DOOR 1–4 RELAY: 4x form C NO/NC Dry: max 4 A at 30 V DC Wet: DC output <sup>b</sup> : 12/24 V DC, jumper configurable, total combined of max 3.8 A at 12 V DC or max 1.5 A at 24 V DC, max 46 W DOOR 5–8 RELAY: 4x form C NO/NC Dry: max 4 A at 30 V DC Wet: DC output <sup>b</sup> : 12/24 V DC, jumper configurable, max 3.8 A at 12 V DC, max 1.5 A at 24 V DC, max 46 W DOOR 1–4 AUX relay: 4x form C relay, NO/NC Dry: max 2 A at 30 V DC DOOR 5–8 AUX relay: 4x form C relay, NO/NC Dry: max 2 A at 30 V DC
<b>Digital I/O</b>	<b>Input connector</b> 3x digital input, 0–30 V DC, possible to supervise between 0–12 V DC (4 states) 1x 12 V DC output <sup>b</sup> , max 190 mA <b>Output connector</b> 3x digital output <sup>b</sup> , open drain, 0–30 V DC, max 100 mA <b>AUX I/O connector</b> 2x configurable inputs or outputs Input: digital input, 0–30 V DC, possible to supervise (parallel connection) between 0–12 V DC (4 states) Output <sup>b</sup> : open drain, 0–30 V DC, max 100 mA 1x 12 V DC output <sup>b</sup> , max 250 mA
<b>External</b>	1x external tamper digital input, 0–30 V DC, possible to supervise between 0–12 V DC (4 states) 1x alarm digital input, 0–30 V DC, possible to supervise between 0–12 V DC (4 states)
<b>Supervised input</b>	Configurable input for Tamper, Alarm, I1–I3, REX, DPS, and AUX IO Programmable end-of-line resistors (serial connection: 1 K, 2.2 K, 4.7 K and 10 K, parallel connection: 4.7 K and 22 K), 1 %, ¼ watt standard One supervised input dedicated for cabinet tamper
<b>Cable requirements</b>	
	Wire size for connectors: CUL/UL: AWG 30–14 DC power: AWG 16–14, qualified for up to 3 m (10 ft) Relay: AWG 16–14, qualified for up to 200 m (656 ft) Ethernet and PoE: STP CAT 5e or higher Reader data (RS485): 1 twisted pair, AWG 26–14, qualified for up to 1000 m (3281 ft) Reader powered by controller (RS485): AWG 22–14, qualified for up to 200 m (656 ft) <sup>c</sup> I/Os as inputs: AWG 24–14, qualified for up to 200 m (656 ft)
<b>System on chip (SoC)</b>	
<b>Memory</b>	512 MB RAM, 2 GB Flash
<b>Network</b>	
<b>Network protocols</b>	IPv4, IPv6, HTTP, HTTPS <sup>d</sup> , TLS <sup>d</sup> , QoS Layer 3 DiffServ, SMTP, mDNS (Bonjour), UPnP <sup>®</sup> , SNMP v1/v2c/v3 (MIB-II), DNS/DNSv6, DDNS, NTP, RTSP, RTP, TCP, UDP, IGMPv1/v2/v3, DHCPv4/v6, SOCKS, SSH, MQTT v3.1.1, Syslog
<b>System integration</b>	
<b>Application Programming Interface</b>	Open API for software integration, including VAPIX <sup>®</sup> , metadata and AXIS Camera Application Platform (ACAP); specifications at <a href="https://axis.com/developer-community">axis.com/developer-community</a> . ACAP includes Native SDK. One-click cloud connection
<b>Tamper detection</b>	Reader tamper Tilting, vibration
<b>Approvals</b>	
<b>Product markings</b>	CE, FCC, ICES, KC, RCM, UL/cUL, VCCI, WEEE
<b>Supply chain</b>	TAA compliant
<b>EMC</b>	CISPR 35, CISPR 32 Class A, EN 55035, EN 55032 Class A, EN 50130-4, EN 61000-6-1, EN 61000-6-2 Australia/New Zealand: RCM AS/NZS CISPR 32 Class A Canada: ICES(A)/NMB(A) Japan: VCCI Class A Korea: KS C 9835, KS C 9832 Class A USA: FCC Part 15 Subpart B Class A
<b>Environment</b>	IEC 60068-2-1, IEC 60068-2-2, IEC 60068-2-6, IEC 60068-2-14, IEC 60068-2-27, IEC 60068-2-78
<b>Safety</b>	CAN/CSA C22.2 No. 62368-1 ed. 3, IEC/EN/UL 62368-1 ed. 3, RCM AS/NZS 62368.1:2022, UL 2043
<b>Cybersecurity</b>	ETSI EN 303 645
<b>Cybersecurity</b>	
<b>Edge security</b>	<b>Software:</b> Signed firmware, brute force delay protection, digest authentication, password protection <b>Hardware:</b> Axis Edge Vault cybersecurity platform Secure element (CC EAL 6+), secure keystore, secure boot
<b>Network security</b>	IEEE 802.1X (EAP-TLS) <sup>d</sup> , IEEE 802.1AR, HTTPS/HSTS <sup>d</sup> , TLS v1.2/v1.3 <sup>d</sup> , Network Time Security (NTS), X.509 Certificate PKI, IP address filtering
<b>Documentation</b>	<i>AXIS OS Hardening Guide</i> <i>Axis Vulnerability Management Policy</i> <i>Axis Security Development Model</i> AXIS OS Software Bill of Material (SBOM) To download documents, go to <a href="https://axis.com/support/cybersecurity/resources">axis.com/support/cybersecurity/resources</a> To read more about Axis cybersecurity support, go to <a href="https://axis.com/cybersecurity">axis.com/cybersecurity</a>
<b>General</b>	
<b>Casing</b>	Steel Color: white NCS S 1002-B
<b>Mounting</b>	DIN rail mount, cabinet mount <sup>e</sup>
<b>Connectors</b>	Network: Shielded RJ45 10BASE-T/100BASE-TX/1000BASE-T PoE I/O: Terminal blocks for DC power, inputs/outputs, RS485, relay. Detachable and color coded connectors for ease of installation. Wire size for connectors: CUL/UL: AWG 30–14
<b>Operating conditions</b>	–40 °C to 55 °C (–40 °F to 131 °F) Conditional maximum temperature <sup>f</sup> : 70 °C (158 °F) Humidity 10–85% RH (non-condensing)

<b>Storage conditions</b>	-40 °C to 70 °C (-40 °F to 158 °F) Humidity 5–95% RH (non-condensing)
<b>Dimensions</b>	For the overall product dimensions, see the dimension drawing in this datasheet.
<b>Weight</b>	1330 g (2.9 lb)
<b>Box content</b>	door controller, installation guide, connector kit (mounted), grounding kit, splicing connectors
<b>Optional accessories</b>	AXIS TA4711 Access Card AXIS TA4712 Key Fob AXIS TA1901 DIN Rail Clip AXIS TA1902 Access Control Connector Kit <sup>9</sup> AXIS 30 W Midspan AXIS 30 W Midspan AC/DC <sup>9</sup> AXIS T8006 PS12 <sup>9</sup> For more accessories, go to <a href="https://axis.com/products/axis-a1810-b">axis.com/products/axis-a1810-b</a>
<b>System tools</b>	AXIS Site Designer, AXIS Device Manager, product selector, accessory selector Available at <a href="https://axis.com">axis.com</a>
<b>Languages</b>	English, German, French, Spanish, Italian, Russian, Simplified Chinese, Japanese, Korean, Portuguese, Polish, Traditional Chinese
<b>Warranty</b>	5-year warranty, see <a href="https://axis.com/warranty">axis.com/warranty</a>
<b>Part numbers</b>	Available at <a href="https://axis.com/products/axis-a1810-b#part-numbers">axis.com/products/axis-a1810-b#part-numbers</a>

<b>Sustainability</b>	
<b>Substance control</b>	PVC free RoHS in accordance with EU RoHS Directive 2011/65/EU/ and EN 63000:2018 REACH in accordance with (EC) No 1907/2006. For SCIP UUID, see <a href="https://echa.europa.eu">echa.europa.eu</a>
<b>Materials</b>	Screened for conflict minerals in accordance with OECD guidelines To read more about sustainability at Axis, go to <a href="https://axis.com/about-axis/sustainability">axis.com/about-axis/sustainability</a>
<b>Environmental responsibility</b>	<a href="https://axis.com/environmental-responsibility">axis.com/environmental-responsibility</a> Axis Communications is a signatory of the UN Global Compact, read more at <a href="https://unglobalcompact.org">unglobalcompact.org</a>
<ul style="list-style-type: none"> <li>a. <i>Requires additional accessory AXIS TA1101-B</i></li> <li>b. <i>All outputs have over current protection circuits with automatic retry.</i></li> <li>c. <i>Depending on the reader's voltage and current input range. Evaluated with A4020-E and A4120-E.</i></li> <li>d. <i>This product includes software developed by the OpenSSL Project for use in the OpenSSL Toolkit. (openssl.org), and cryptographic software written by Eric Young (eay@cryptsoft.com).</i></li> <li>e. <i>Shall be mounted in UL listed UL 294 enclosure with tamper switch.</i></li> <li>f. <i>Only DC IN as a power source. The lock(s) should be externally powered. Dry contact only.</i></li> <li>g. <i>Not intended for UL 294</i></li> </ul>	



## Highlighted capabilities

### Axis Edge Vault

Axis Edge Vault is the hardware-based cybersecurity platform that safeguards the Axis device. It forms the foundation that all secure operations depend on and offer features to protect the device's identity, safeguard its integrity and protect sensitive information from unauthorized access. For instance, **secure boot** ensures that a device can boot only with **signed OS**, which prevents physical supply chain tampering. With signed OS, the device is also able to validate new device software before accepting to install it. And the **secure keystore** is the critical building-block for protect-

ing cryptographic information used for secure communication (IEEE 802.1X, HTTPS, Axis device ID, access control keys etc.) against malicious extraction in the event of a security breach. The secure keystore and secure connections are provided through a Common Criteria or FIPS 140 certified hardware-based cryptographic computing module.

To read more about Axis Edge Vault, go to [axis.com/solutions/edge-vault](https://axis.com/solutions/edge-vault).

For more information, see [axis.com/glossary](https://axis.com/glossary)