

**DS-UPS1200-R#UK**  
**1200VA/720W, Backup UPS with built-in battery**



- Built-in AVR
- Auto restart while AC is recovering
- Super fast charging
- Wide input voltage range
- Overload protection
- Short circuit protection
- Surge protection

## ▪ Specification

<b>Power</b>	
UPS Capacity	1200VA / 720W
<b>Input</b>	
Input Voltage Range	162VAC to 290 VAC
Input Frequency	50/60 Hz self-adaptive
Plug Type	UK TYPE G
<b>Output</b>	
Output Voltage Range	230VAC ± 10%
Output Frequency	50/60 Hz ± 0.5 Hz self-adaptive
Transfer Time	≤ 10 ms
Waveform	Simulated Sinewave
Outlet Type	UK TYPE G
Outlet Number	4
<b>Battery</b>	
Battery Type	12 V / 7 Ah x 2, lead-acid battery
Recharge Time	6-8 hours recover to 90% capacity
Typical Backup Time	Run time at 200w: 20-25 min
<b>Interface</b>	
Communicate Ports	No
<b>Protection</b>	
Full Protection	Surge protection,Overload protection,Discharge protection,Overcharge protection
<b>Indicator</b>	
Display	LED indicator Line mode: Solid green led lighting Battery mode: Solid yellow led flash Fault mode: Solid red led lighting
Alarm	Battery mode: Sounding every 10 seconds. Low battery : Sounding every second. Over load : Sounding every 0.5 seconds. Fault: Continuously sounding.
<b>General</b>	
Operating Temperature	0 °C to 40 °C (32 °F to 104 °F )
Operating Humidity	0% to 90% (non-condensing)
Dimension	350 mm × 149 mm × 162 mm (13.78" × 5.87" × 6.38")
Weight	Approx. 8.9 kg (19.62 lb)

## ▪ Available Model

DS-UPS1200-R/UK(HWDZ)

## ▪ Dimension

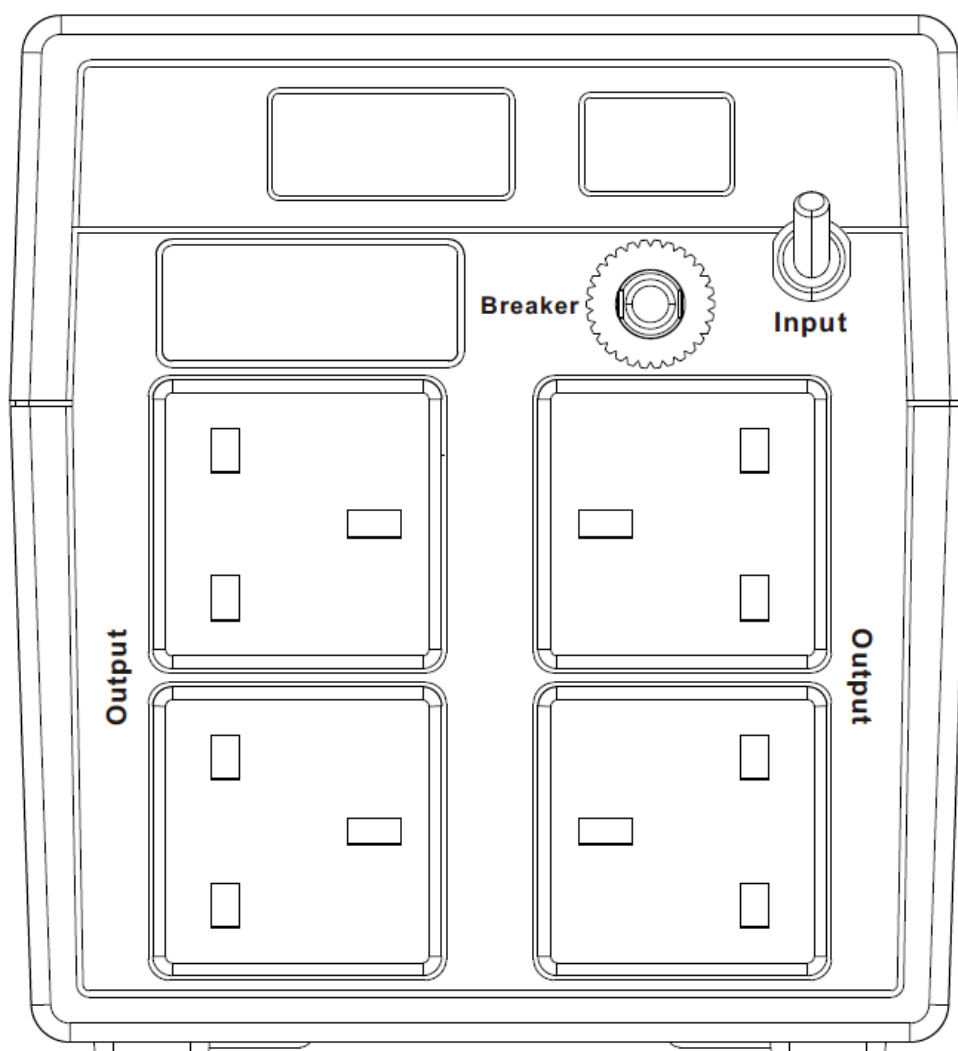
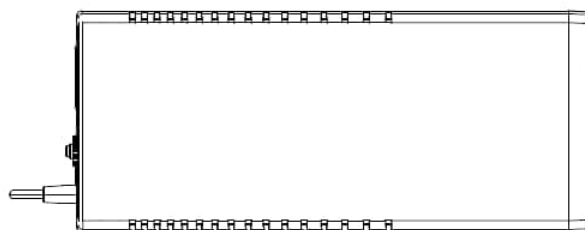
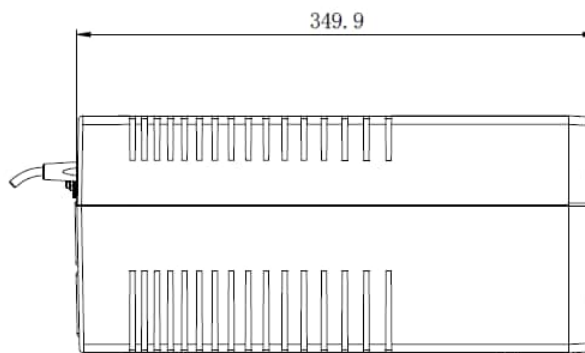
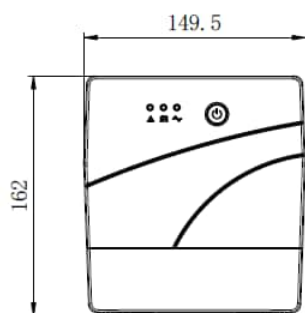

# See Far, Go Further



[www.hikvision.com](http://www.hikvision.com)  
[support@hikvision.com](mailto:support@hikvision.com)

