



TAMPER-PROOF ETHERNET & POE OVER COAX

HIGHWIRE™

BASE 8

LINKLOCK



HIGHWIRE Powerstar Base 8 LINKLOCK can be 19" rack-mounted

LINKLOCK™
technology provides
secure tamper-proof
network connections
over coax cable

LINKLOCK options are available in Veracity's high performance HIGHWIRE Powerstar Base 4 and Base 8 Ethernet and POE over coax devices.

- | Tamper-proof Ethernet and POE over coax
- | 8 tamper-proof channels per Base unit
- | Tampering or interference with cabling shuts down channel
- | Relay contact alarm output on tamper, with reset pins
- | 32 POE or POE Plus channels in 1U with four Base units
- | Automatic configuration for simple installation
- | Full duplex 100Base-TX performance on each coax

LINKLOCK™ provides a secure barrier to unauthorised access to your network

LINKLOCK™ detects any disconnection/reconnection or tampering with any part of the cabling between the Base unit and the IP camera or other POE device.

When Is LINKLOCK Required ?

Any externally mounted IP cameras potentially leave an exposed network connection which could be used by attackers to access the rest of the network - to disable the surveillance system for example. This may also expose the corporate network as this is often bridged to the surveillance network. LINKLOCK prevents such attacks by completely disconnecting power and data for that channel whenever it detects a cable disconnection or reconnection or even any tampering such as "tapping in" to the coax or network cables.

How Does LINKLOCK Work ?

LINKLOCK works by constantly monitoring the POE power connection and data transmissions. It can detect even subtle changes or interruptions in the data transmission characteristics which will trigger disconnection and alarm, whilst remaining extremely robust against false alarms.

Once triggered and disconnected, the channel can be re-established via the reset pins after suitable action is taken to determine the cause of the alarm (i.e. a possible attacker).

HIGHWIRE Powerstar Base LINKLOCK Option

LINKLOCK™ is available as an option on Veracity's HIGHWIRE Powerstar Base 4 and Base 8 models of Ethernet and POE over coax adaptors.

The Base unit accepts external power via a POE switch or a DC power supply. It sends power over the coax link to the Camera unit. The camera unit in turn provides POE (Power-over-Ethernet) to the IP camera.

See HIGHWIRE Powerstar Base 4 or Base 8 datasheets for full information on HIGHWIRE.

HIGHWIRE POWERSTAR BASE 8 with LINKLOCK Connection Diagram

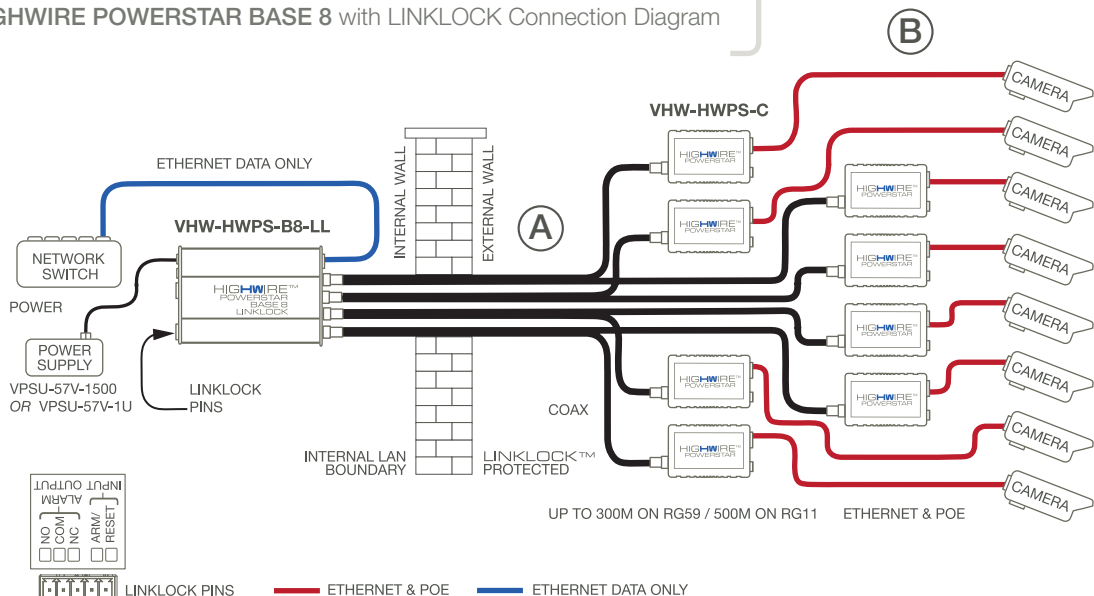



Rackmount | Four rack-mounted HIGHWIRE Powerstar Base 8 Linklock units assembled with a Veracity 1U PSU.



Front | 8 coax links with status LEDs, plus a Gigabit uplink port.

Rear | Power connectors (screw terminal or micro-fit) with SFP socket for fibre module and LINKLOCK Pins

LINKLOCK Protection

LINKLOCK provides protection to both the coaxial cable and the Ethernet cable connecting the IP camera to the HIGHWIRE Camera unit (sections A and B in the diagram opposite).

LINKLOCK disconnection (blocking mode) is triggered when:

- The coaxial cable A is disconnected
- The Ethernet cable B is disconnected
- The coaxial cable A is disrupted
- The Ethernet cable B is disrupted

Note that having a secure or encrypted link over the coax alone does not prevent intrusion as the Ethernet link to the camera would still be open and unsecured without LINKLOCK.

When blocking mode is enabled, all external equipment is immediately isolated from the internal LAN.

The internally-located HIGHWIRE Powerstar Base 4 or 8 unit will :

- Remove POE Power from the coaxial cable (this disconnects and switches off the HIGHWIRE Camera unit and IP camera).
- Completely disable its coaxial network interface for the triggered channel only.
- Close the alarm relay contact and indicate the alarm channel with a red LED.

Restoring the Connection

LINKLOCK blocking mode is constant until reset. For complete security it cannot be reversed through the external network or coaxial interface. The HIGHWIRE LINKLOCK Base unit must be physically reset through the reset pins on the alarm interface connections. A push-button or relay is normally wired to the reset pins. If desired, network-controlled relay devices may be used to allow remote reset from any secure part of the network.

Typically, the camera disconnection would be used to trigger an alarm within the VMS (Video Management System) or NVR (Network Video Recorder).

Secure barrier to unauthorised access in high security sites, such as airports, banks and critical infrastructure sites.



TECHNICAL SPECIFICATION

HIGHWIRE™
BASE 8
LINKLOCK

HIGHWIRE INTERFACE	<p>Connector type Cable type Range Bandwidth</p>	<p>BNC 75 Ohm x 8 Any 75 Ohm coaxial (other impedances supported) Up to 300m [1000ft] on RG59 or 500 metres [1640 feet] on RG11 at full rate 200 Mbps (total up + down) x 8</p>
ETHERNET INTERFACE	<p>Connector type Cable type Rate</p>	<p>RJ45 with optional SFP socket for fibre Cat 5/6 Patch or crossover, auto-detected or as per optional SFP device Gigabit Ethernet, Full duplex (1000Base-TX) with auto-negotiation</p>
LINKLOCK INTERFACE	<p>LINKLOCK Trigger LINKLOCK Alarm LINKLOCK Reset Connector</p>	<p>On disconnection or tamper of coax or network cable Relay switch output (NO, COM, NC) on screw terminals connector Via reset pins on screw terminals connector 5-pin removable screw terminal connector</p>
LEDS	<p>Status indicators</p>	<p>HIGHWIRE coax link - flashes red when LINKLOCK is triggered Ethernet link/activity (BASE) - flashes red when LINKLOCK is triggered See Quickstart Guide for LED indicator table and diagnostics. Guide also online</p>
POWER	<p>Unit power POE Out Power input</p>	<p>10W rising to 20W under full POE load IEEE 802.3af (POE) or IEEE 802.3at (POE Plus) up to 25W per channel 57V DC, up to 6A via a 2 pin detachable screw terminal (supplied) or a 2 pin Micro-Fit power connector</p>
PHYSICAL/ENVIRONMENTAL	<p>Dimensions Weight Operating temperature Relative humidity Compliance</p>	<p>L 173mm (including BNC connectors) W 110mm H40mm 572g [20.2oz] 0°C to 40°C [32°F to 104°F] 85% non-condensing FCC, CE, RoHS, REACH</p>
PRODUCT CODES	<p>VHW-HWPS-B8-LL VHW-HWPS-B4-LL VHW-HWPS-C VPSU-57V-1500 VPSU-57V-1U-UK VPSU-57V-1U-EU VPSU-57V-1U-US</p>	<p>HIGHWIRE Powerstar Base 8 LINKLOCK™ eight channel unit with LINKLOCK HIGHWIRE Powerstar Base 4 LINKLOCK™ - four channel unit with LINKLOCK HIGHWIRE Powerstar™ Camera - single channel EOC adaptor for camera end 57V DC, 1500mA (80W max) power supply 57V DC, 8800mA (400W max) power supply, with cable for UK 57V DC, 8800mA (400W max) power supply, with cable for EU 57V DC, 8800mA (350W max) power supply, with cable for US</p>

Only the Base unit requires the LINKLOCK feature. These are used with standard Camera units.

**Americas Sales**

Veracity USA Inc.
17000 Preston Road
Suite 120
Dallas
TX 75248
USA
Tel: 1-800-679-1590
Fax: 1-800-679-0714
www.veracityglobal.com
sales@veracityusa.com

EMEA Sales

Veracity UK Ltd
Prestwick International Aerospace Park
4 Dow Road
Prestwick
KA9 2TU
UK
Tel +44 (0) 1292 264967
Fax +44 (0) 845 528 1081
www.veracityglobal.com
sales@veracityuk.com

© Veracity UK Ltd 2017 All rights reserved. WV1.0 UK

Under no circumstances should this document be reproduced, distributed or changed, partially or wholly, without written, formal authorisation from Veracity UK Ltd.

HIGHWIRE POWERSTAR, HIGHWIRE POWERSTAR BASE 8 or BASE 4 and LINKLOCK, are trademarks of Veracity UK Ltd