



AXIS M42 Network Camera Series

AXIS M4206-V Network Camera

AXIS M4206-LV Network Camera

AXIS M4215-V Network Camera

AXIS M4215-LV Network Camera

AXIS M4216-V Network Camera

AXIS M4216-LV Network Camera

AXIS M4218-V Network Camera

AXIS M4218-LV Network Camera

Repainting instructions

AXIS M42 Network Camera Series

Impact on warranty

Impact on warranty

This product is approved for repaint by Axis, provided that you follow the instructions in this document and at axis.com/warranty-implication-when-repainting.

Risks with repainting

There are several risks when disassembling or assembling an Axis product. There is always a certain yield loss during assembly. Training of operators and the use of correct tools mediates some of the problems but they can never be fully avoided. Some of the risks include:

ESD Damage – Always handle the product in an ESD safe environment. Even if precautions are taken there is always a risk of ESD damage. The damage can remain undetected and cause problems during the lifetime of the equipment.

Dust contamination – Opening a camera may expose the lens and sensor to dust or paint. Dust will affect the optical performance. Lenses need to be disassembled in a dust-free environment, preferably a cleanroom.

Paint overspray – Masking the different components of the equipment is critical. Failure to mask sensitive areas can cause problems with assembling the equipment. Any areas that are not painted at factory or have a different surface treatment than the rest of the parts (threads, ground and electrical contact surfaces) must also be masked to ensure function.

AXIS M42 Network Camera Series

Repaint the product

Repaint the product

Preparations

- If applicable, disassemble the device according to the instructions in this document.
- Clean all parts that will be repainted thoroughly to remove grease, dust, or oil.
- To ensure reassembly and functionality of the product, mask any openings (for example for screws, LED indicators, or microphones) before you paint.
- To avoid unwanted reflections, mask the inside of the weathershield before you paint.

Pretreatment of parts

Depending on the part material and type of coating applied at factory, pretreatment might be necessary for the new coating to adhere well. Before you apply a new coating, we recommend the following pretreatment:

1. If necessary, roughen up the surface with a light sandpaper or similar to increase adhesion. Alternatively, remove the original coating down to base material.
2. Clean the parts properly to remove oil, grease, and dust.
3. If necessary, apply a primer layer suitable for the specific material to increase adhesion to the parts. For outdoor products, we recommend a primer to improve corrosion resistance.

We recommend pretreatment of parts made of the following materials:

- powder coated
- wet painted
- anodised
- chromated
- stainless steel
- other metal
- plastic

AXIS M42 Network Camera Series

Repaint the product

Disassembly

AXIS M42 Network Camera Series

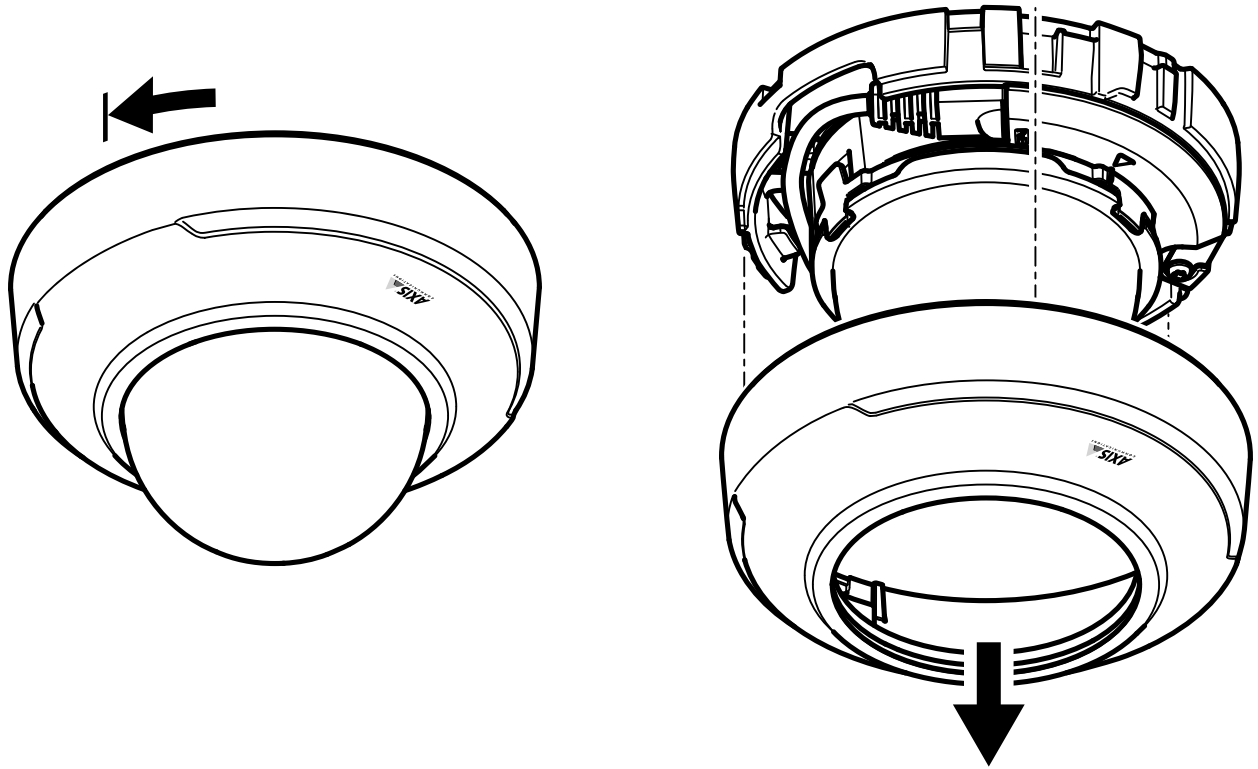

1. Remove the dome cover.

AXIS M42 Network Camera Series

Repaint the product

Repainting

AXIS M42 Network Camera Series

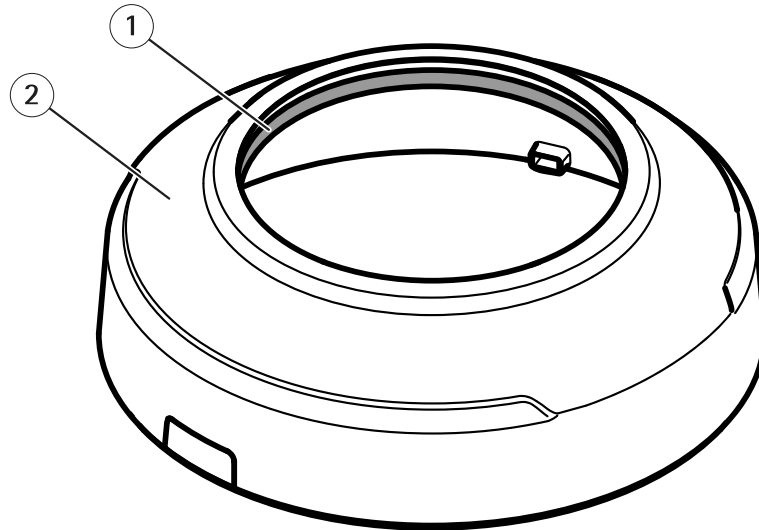

- 1 Gasket
- 2 Dome cover

1. Mask the gasket.
2. Make sure all necessary preparations of the dome cover have been made. See *Preparations on page 3*.
3. Apply a thin and even layer of spray paint according to the instructions of the paint manufacturer.
4. Let the paint dry.
5. To get better coverage and a clearer color, apply a second layer of spray paint.
6. When the paint is dry, remove the masking.

AXIS M42 Network Camera Series

Repaint the product

Reassembly

AXIS M42 Network Camera Series

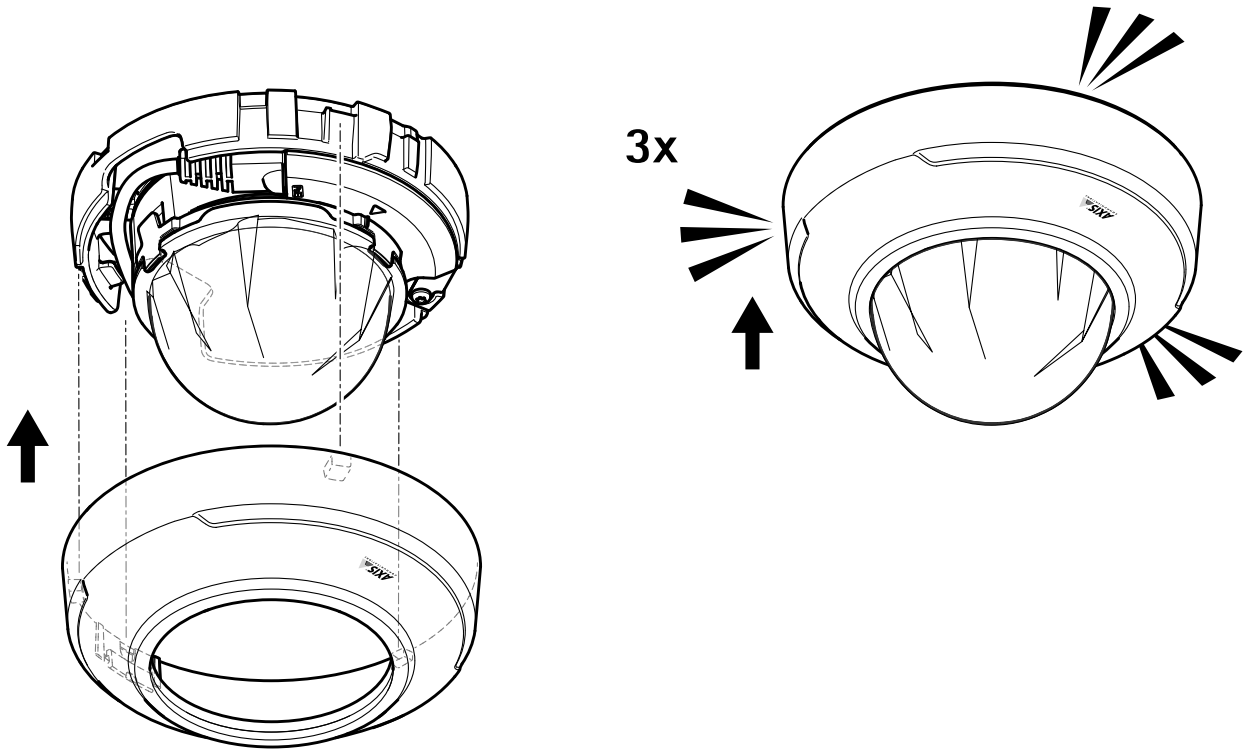

1. Line up the dome cover with the dome and snap the two parts together (3 snaps).

