



Network Camera

Installation Manual

DC-D4831HRX

Before reading this manual



This is a basic installation manual for use of an IDIS network camera. Users who are using this product for the first time, as well as users with experience using comparable products, must read this operation manual carefully before use and heed to the warnings and precautions contained herein while using the product. Safety warnings and precautions contained in this operation manual are intended to promote proper use of the product and thereby prevent accidents and property damage and must be followed at all times. Once you have read this operation manual, keep it at an easily accessible location for future reference.

-  • The manufacturer will not be held responsible for any product damage resulting from the use of unauthorized parts and accessories or from the user's failure to comply with the instructions contained in this manual.
- The information in this document is believed to be accurate as of the date of publication even though explanation about some functions may not be incorporated. The manufacturer is not responsible for any problems resulting from the use thereof. The information contained herein is subject to change without notice. Revisions or new editions to this publication may be issued to incorporate such changes.
- It is recommended that first-time users of this network camera and individuals who are not familiar with its use seek technical assistance from their retailer regarding product installation and use.
- If you need to disassemble the product for functionality expansion or repair purposes, you must contact your retailer and seek professional assistance.
- Both retailers and users should be aware that this product has been certified as being electromagnetically compatible for commercial use. If you have sold or purchased this product unintentionally, please replace with a consumer version.

Safety Symbols

Symbol	Publication	Description
	IEC60417, No.5031	Direct current

In-Text

Symbol	Type	Description
	Caution	Important information concerning a specific function.
	Note	Useful information concerning a specific function.

Safety Precautions

WARNING

RISK OF ELECTRIC SHOCK
DO NOT OPEN

WARNING: TO REDUCE THE RISK OF ELECTRIC SHOCK,
DO NOT REMOVE COVER (OR BACK).
NO USER-SERVICEABLE PARTS INSIDE.
REFER SERVICING TO QUALIFIED SERVICE PERSONNEL.

Important Safeguards

1. Read Instructions

All the safety and operating instructions should be read before the appliance is operated.

2. Retain Instructions

The safety and operating instructions should be retained for future reference.

3. Cleaning

Unplug this equipment from the wall outlet before cleaning it. Do not use liquid aerosol cleaners. Use a damp soft cloth for cleaning.

4. Attachments

Never add any attachments and/or equipment without the approval of the manufacturer as such additions may result in the risk of fire, electric shock or other personal injury.

5. Water and/or Moisture

Do not use this equipment near water or in contact with water.

6. Placing and Accessories

Do not place this equipment on an wall or ceiling that is not strong enough to sustain the camera. The equipment may fall, causing serious injury to a child or adult, and serious damage to the equipment. Wall or shelf mounting should follow the manufacturer's instructions, and should use a mounting kit approved by the manufacturer.



This equipment and cart combination should be moved with care. Quick stops, excessive force, and uneven surfaces may cause the equipment and cart combination to overturn.

Do not place this equipment in an enclosed space. Sufficient ventilation is required to prevent an increase in ambient temperature which can cause malfunction or the risk of fire.

7. Power Sources

This equipment should be operated only from the type of power source indicated on the marking label. If you are not sure of the type of power, please consult your equipment dealer or local power company. You may want to install a UPS (Uninterruptible Power Supply) system for safe operation in order to prevent damage caused by an unexpected power stoppage. Any questions concerning UPS, consult your UPS retailer.

This equipment should be remain readily operable.

8. Power Cord

Operator or installer must remove power and TNT connections before handling the equipment.

9. Lightning

For added protection for this equipment during a lightning storm, or when it is left unattended and unused for long periods of time, unplug it from the wall outlet and disconnect the antenna or cable system. This will prevent damage to the equipment due to lightning and power-line surges. If thunder or lightning is common where the equipment is installed, use a surge protection device.

10. Overloading

Do not overload wall outlets and extension cords as this can result in the risk of fire or electric shock.

11. Objects and Liquids

Never push objects of any kind through openings of this equipment as they may touch dangerous voltage points or short out parts that could result in a fire or electric shock. Never spill liquid of any kind on the equipment.

12. Servicing

Do not attempt to service this equipment yourself. Refer all servicing to qualified service personnel.

13. Damage requiring Service

Unplug this equipment from the wall outlet and refer servicing to qualified service personnel under the following conditions:

- When the power-supply cord or the plug has been damaged.
- If liquid is spilled, or objects have hit the equipment.
- If the equipment has been exposed to rain or water.
- If the equipment does not operate normally by following the operating instructions, adjust only those controls that are covered by the operating instructions as an improper adjustment of other controls may result in damage and will often require extensive work by a qualified technician to restore the equipment to its normal operation.
- If the equipment has been dropped, or the cabinet damaged.
- When the equipment exhibits a distinct change in performance — this indicates a need for service.

14. Replacement Parts

When replacement parts are required, be sure the service technician has used replacement parts specified by the manufacturer or that have the same characteristics as the original part. Unauthorized substitutions may result in fire, electric shock or other hazards.

15. Safety Check

Upon completion of any service or repairs to this equipment, ask the service technician to perform safety checks to determine that the equipment is in proper operating condition.

16. Field Installation

This installation should be made by a qualified service person and should conform to all local codes.

17. Correct Batteries

Warning: Risk of explosion if battery is replaced by an incorrect type. Replace only with the same or equivalent type.

Dispose of used batteries according to the instructions.

The battery shall not be exposed to excessive heat such as sunshine, fire or the like.

18. Tmra

A manufacturer's maximum recommended ambient temperature (Tmra) for the equipment must be specified so that the customer and installer may determine a suitable maximum operating environment for the equipment.

Before reading this manual

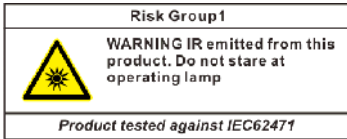

Warning: This product emits infrared light. Do not look into the IR LED.

FCC Compliance Statement

THIS EQUIPMENT HAS BEEN TESTED AND FOUND TO COMPLY WITH THE LIMITS FOR A CLASS A DIGITAL DEVICE, PURSUANT TO PART 15 OF THE FCC RULES. THESE LIMITS ARE DESIGNED TO PROVIDE REASONABLE PROTECTION AGAINST HARMFUL INTERFERENCE WHEN THE EQUIPMENT IS OPERATED IN A COMMERCIAL ENVIRONMENT. THIS EQUIPMENT GENERATES, USES, AND CAN RADIATE RADIO FREQUENCY ENERGY AND IF NOT INSTALLED AND USED IN ACCORDANCE WITH THE INSTRUCTION MANUAL, MAY CAUSE HARMFUL INTERFERENCE TO RADIO COMMUNICATIONS. OPERATION OF THIS EQUIPMENT IN A RESIDENTIAL AREA IS LIKELY TO CAUSE HARMFUL INTERFERENCE, IN WHICH CASE USERS WILL BE REQUIRED TO CORRECT THE INTERFERENCE AT THEIR OWN EXPENSE.

WARNING: CHANGES OR MODIFICATIONS NOT EXPRESSLY APPROVED BY THE PARTY RESPONSIBLE FOR COMPLIANCE COULD VOID THE USER'S AUTHORITY TO OPERATE THE EQUIPMENT. THIS CLASS OF DIGITAL APPARATUS MEETS ALL REQUIREMENTS OF THE CANADIAN INTERFERENCE CAUSING EQUIPMENT REGULATIONS.

WEEE (Waste Electrical & Electronic Equipment)

Correct Disposal of This Product

(Applicable in the European Union and other European countries with separate collection systems)



This marking shown on the product or its literature, indicates that it should not be disposed with other household wastes at the end of its working life. To prevent possible harm to the environment or human health from uncontrolled waste disposal, please separate this from other types of wastes and recycle it responsibly to promote the sustainable reuse of material resources.

Household users should contact either the retailer where they purchased this product, or their local government office, for details of where and how they can take this item for environmentally safe recycling.

Business users should contact their supplier and check the terms and conditions of the purchase contract. This product should not be mixed with other commercial wastes for disposal.

Copyright

© 2020 IDIS Co., Ltd.

IDIS Co., Ltd. reserves all rights concerning this operation manual.

Use or duplication of this operation manual in part or whole without the prior consent of IDIS Co., Ltd. is strictly prohibited.

Contents of this operation manual are subject to change without prior notice for reasons such as functionality enhancements.

Registered Trademarks

IDIS is a registered trademark of IDIS Co., Ltd.

Other company and product names are registered trademarks of their respective owners.

The software included in this product contains some Open Sources. You may obtain the corresponding source code which we have to distribute according to the license policy. For more information, refer to **System > General** page. This product includes software developed by the University of California, Berkeley and its contributors, and software developed by the OpenSSL Project for use in the OpenSSL Toolkit (<http://www.openssl.org/>). Also, this product includes cryptographic software written by Eric Young (ey@cryptsoft.com).

Table of Contents

1

Part 1 – Introduction.....	6
Product Features	6
Accessories.....	8
Overview	9
Dome Cover	9
Body.....	9
Factory Reset	12
Lens	12
Installation	12
Removing the Dome Cover	12
Inserting a SD Memory Card	13
Installation.....	13
Angle Adjustment.....	15
Closing the Dome Cover.....	15
Dimension	16

2

Part 2 - Camera Connection	17
With DirectIP™ NVR-based Layout.....	17
With non DirectIP™ NVR-based Layout	18

3

Part 3 - Appendix.....	19
Troubleshooting	19
Specifications	20

Part 1 – Introduction

Product Features

DC-D4831HRX is IP-based network cameras that compress and transmit video over Ethernet. You can use the IDIS Discovery program to change network camera settings or the IDIS Solution Suite Compact program to manage multiple network cameras. In addition, the embedded web server (IDIS Web) lets you remotely view live video or scan recorded video using a web browser. In addition, you can use the IDIS Solution Suite Compact to manage network cameras and view/record video.



In this operation manual, the term **Remote System** refers to the computer on which the remote program (IDIS Solution Suite Compact or IDIS Web) is running.

- Supports DirectIP mode working with a DirectIP™ NVR that allows users to simply set up all required configurations without a PC
- Supports ONVIF protocol (Core specification version 16.12, Profile S)
- Multi-streaming for high-resolution and high-quality video monitoring and simultaneous recording in real-time as well as flexible configurations for those
 - Supports H.265 and H.264 video compression and M-JPEG still image compression algorithms
 - Supports 4-stage video compression rate and multiple compression resolutions
 - Two-way audio communication support for remote audio dialog
 - Video stream buffering to counter pre-/post-event buffering and network delays for improved network recording reliability
 - Remote monitoring via web browser or remote software
 - Automatic web casting code (HTML) generation
 - Up to 10 simultaneous remote monitoring connections
 - IP filtering, HTTPS, SSL, IEEE 802.1X, and configurable user authority levels for greater security
 - Network bandwidth limitation and MAT features for more efficient use of network bandwidth

- Easy network access via UPnP (Universal Plug and Play) function and embedded mDNS (Multicast DNS) protocol
 - Wide dynamic range compensation (True WDR) for improved video quality in high-contrast situations
 - Slow shutter support for improved low-lighting video capture performance
 - Day & Night feature (built-in IR cut filter changer)
 - Quick and easy firmware upgrade over the network
 - Redundant firmware and auto recovery features for improved system stability
 - Network-based integrated management of multiple network cameras
 - Multiple event detection modes
 - Backup storage on a micro SD memory card as a safeguard against data loss during network interruptions
 - Supports 12 VDC and PoE (Power over Ethernet)
 - Includes a motorized focus and zoom lens
 - Features a built-in heater for continued use in subzero temperature conditions
 - IK10 and IP67-level for water resistant protection and dust proof against rain and dust
- Remote monitoring and recording via multi streaming are available using the IDIS Solution Suite Compact program. For more information on using IDIS Solution Suite Compact, refer to its **operation manual**.
- There is a limit to the number of users allowed to connect remotely via the Internet at the same time.

Accessories

Upon purchasing the product, check inside the box to make sure all the following accessories are included.

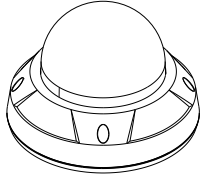

Network Camera

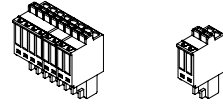

Terminal Blocks (2 ea.)

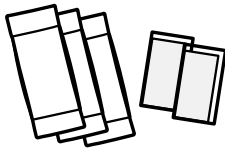

Desiccant (3 ea.), double-sided tape (3 ea.)



Allen Wrench

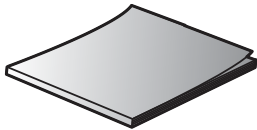

Quick Guide

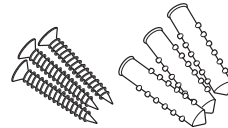

Screws (3 ea.)

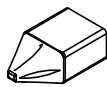

Protect Connector

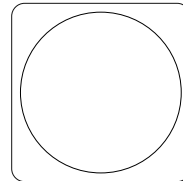

Guide Pattern

Overview

Dome Cover

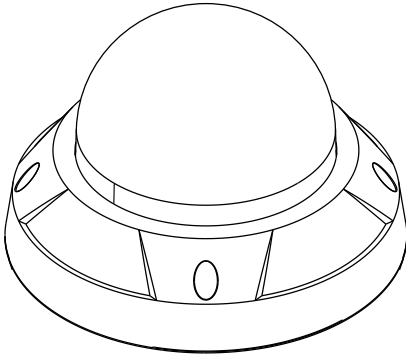

Body

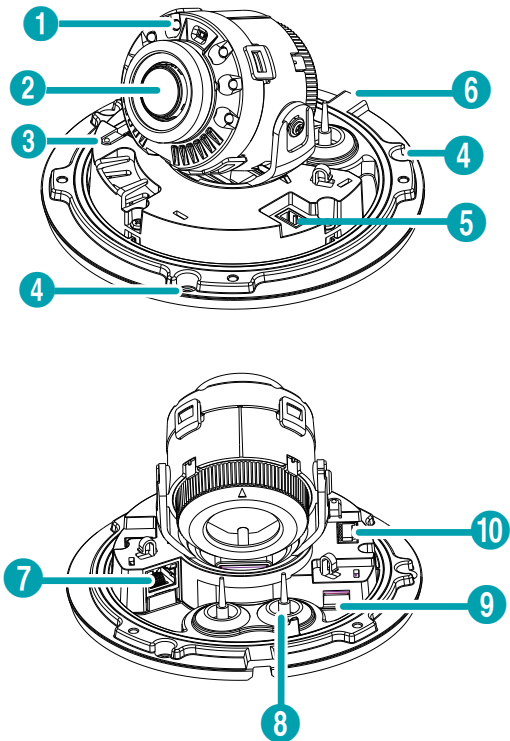

①	IR LED
②	Lens
③	Factory Reset Button
④	Wall/Ceiling Installation Hole
⑤	Power
⑥	Dome Cover Assembly Part
⑦	Network Port
⑧	Cable Rubber
⑨	SD Memory Card Slot
⑩	Alarm I/O, Audio I/O

• **IR LED**

A sensor in the middle monitors lighting levels and activates the IR LED during low-lighting conditions.

• **Lens**

A motorized focus and zoom lens is installed.

• **Factory Reset Button**

Restores the camera's default factory settings. For more information, refer to the **Factory Reset**.

• **Wall/Ceiling Installation Hole**

Used to screw the camera in place on a wall or a ceiling.

• **Power (DC12V)**

Connect this to the power adapter.

• **Dome Cover Assembly Part**

The dome cover will be combined on this part.

• **Network Port**

Connect a network cable with an RJ-45 connector to this port. If using a PoE switch, you can supply power to the camera using an Ethernet cable. For more information on PoE switch use, refer to the switch manufacturer's operation manual. You can configure, manage, and upgrade this camera and monitor its images from a remote computer over the network. For more information on network connection setup, refer to the **IDIS Discovery operation manual**.



The table below shows the network cable specifications.

<The network cable specifications>

Item	Content	Note
Connector	RJ-45	
Ethernet	10/100 Base	10/100 Mbps
Cable	UTP Category 5e or higher	
Maximum length	100m	
PoE	IEEE 802.3af, Class 3	

• **Cable Rubber**

Foreign matter may get inside if reconnecting is failed after removing the cable access hole rubber. A silicon finish may be required to maintain waterproof performance. For more information refer to the **Installation** part.

• **SD Memory Card Slot**

Used to insert a micro SD memory card into the camera. (An SLC (Single Level Cell) or MLC (Multi Level Cell) card by San Disk or Transcend is recommended.



- To remove/insert the SD memory card or perform the factory reset, make sure that the lens rear side's cover is joined properly when screwing it. Otherwise, the IP66 level is not guaranteed. For more information, contact your product retailer.
- Do not remove the SD memory card while the system is in operation. Removing the card while the system is in operation can cause the system to malfunction and/or corrupt data stored on the SD memory card.
- An SD memory card is a consumable product with a finite service life. Prolonged use will damage the card's memory sectors and result in data loss or memory card failure. Test the SD memory card regularly and replace it whenever necessary.

• **Alarm**

- O (Out):** It is the BJT (Bipolar Junction Transistor) - open collector output. If the voltage and current exceed the specification limit (Max. Load: 30mA, Max. Voltage: 5VDC), the product could be damaged. When connecting the device which exceeds the specification limit, refer to the picture (circuit) below.



If used with an external inductive load(e.g. relay), a diode must be connected in parallel with the load for protection. Otherwise, the product could be damaged.

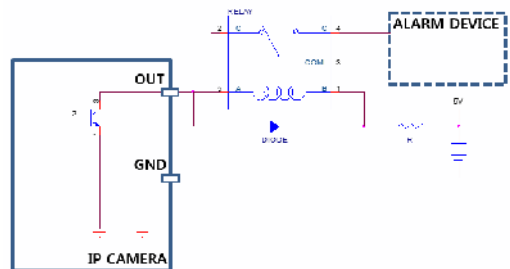

- I (In):** Connect an alarm-in device to this port. (Mechanism: Choose between an NC (Normally Closed) type or an NO (Normally Open) type) → Connect a mechanical or electrical switch to the alarm in port and the GND (ground) connector. Alarm in range is 0V to 5V. In order to detect alarm

input from an electrical switch, the signal must be higher than 4.3V from an NC switch or less than 0.3V from an NO switch and must last for longer than 0.5 seconds.

• **Audio**

- **O (Out):** Connect an amplifier to this port (line out). This device does not feature a built-in audio amplifier unit and therefore requires the user to purchase a separate speaker system with a built-in amplifier.
- **I (In):** Connect an audio source to this port. (Line in)



- Check your local laws and regulations on making video or audio recordings. The user will be held liable for any violation of the law.
- When switching over from 12 VDC to PoE as the power source, the system will be rebooted once the power adapter is disconnected.
- Organize the power cable so that it will not cause people to trip over or become damaged from chairs, cabinets, desks, and other objects in the vicinity. Do not run the power cable underneath carpet or a rug or plug the cable into a power outlet shared by a number of other devices.



- Do not remove the SD memory card while the system is in operation. Removing the card while the system is in operation can cause the system to malfunction and/or corrupt data stored on the SD memory card.
- An SD memory card is a consumable product with a finite service life. Prolonged use will damage the card's memory sectors and result in data loss or memory card failure. Test the SD memory card regularly and replace it whenever necessary.

I/O Connector

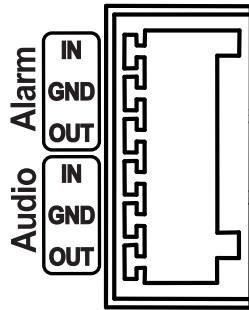

Alarm	In	Alarm In
	GND	Grounding
	Out	Alarm Out (Active Low - Open Collector Output)
Audio	In	Audio In
	GND	Grounding
	Out	Audio Out

Factory Reset

Only use the factory reset button to restore the camera to its factory default settings.

A factory reset will clear all camera settings configured by the user.

- 1 Shut off the power supply.
- 2 Remove the dome cover and then press the reset button down.
- 3 Hold the button down and reconnect the power adapter.
- 4 Once the device turns back on, wait 5 seconds, and then release the reset button.
- 5 The device will go through the resetting process and reboot. All camera settings will be restored to their factory defaults after the reboot.

It's also possible to do a factory reset by pressing and releasing the reset button while the camera is turned on or using the IDIS Discovery program from a remote location. A factory reset will reboot the system. For more information on factory reset, refer to the **IDIS Discovery operation manual**.

Lens

Motorized focus and zoom lens

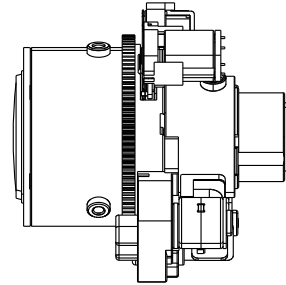

When installing or handling the camera, be careful not to give an impact on the lens to prevent a malfunction from occurring.

Installation

Installation of this product does not require the use of special tools.

For more information on other devices comprising the overall system, refer to their respective **installation manuals**.

Product color and design may vary depending on the model.

Removing the Dome Cover

- 1 Loosen the screws counterclockwise using the allen wrench provided with the product.

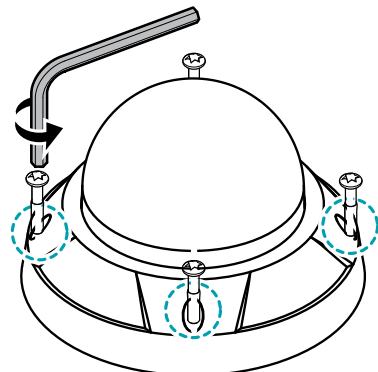

2 Remove the dome cover.

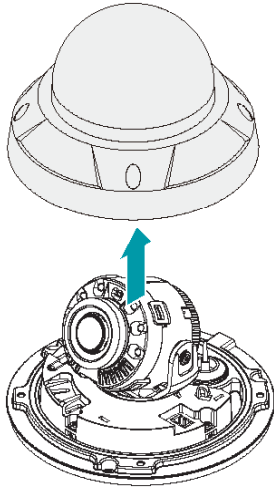

Inserting a SD Memory Card

Insert a SD memory card into the SD memory card slot with the 'micro SD' print facing upward.

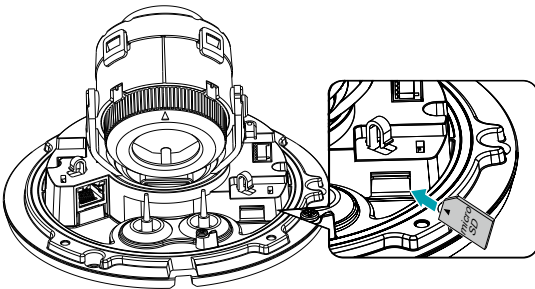

Push the SD memory card until it disengages from the slot, and then pull it out.

Installation

- Check the wall or ceiling to see if it needs to be reinforced. The camera may fall off if the wall or ceiling is not strong enough to support its weight.
- Install the camera in a shaded area. If the camera is installed in direct sunlight, it may be affected adversely.

1 Detach the protrusion part from the cable rubber along the dotted line.

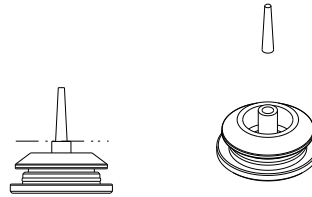

2 Make the LAN cable go through the cable rubber using the protect connector.

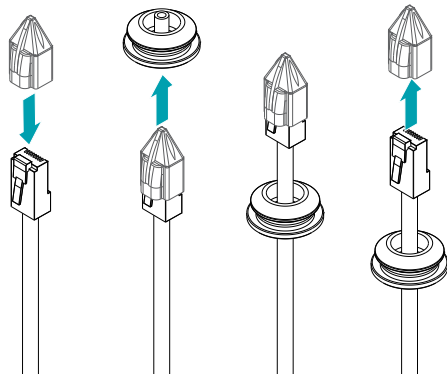

It is recommended to use lubricant to move the LAN cable smoothly.

Part 1 – Introduction

- 3 Pull the cable slightly and arrange the rubber as shown below.

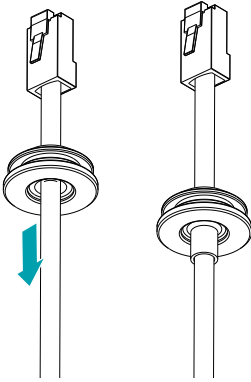

- To pass through a thin cable or more than two cables, it is advised to finish it using silicon to make sure waterproofed perfectly. (Silicon finishing part — refer to bottom image.)

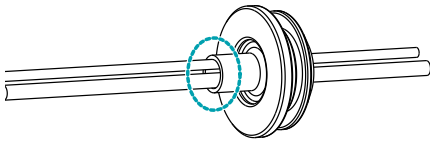

- 4 Assemble the cable rubber to the bottom cover.

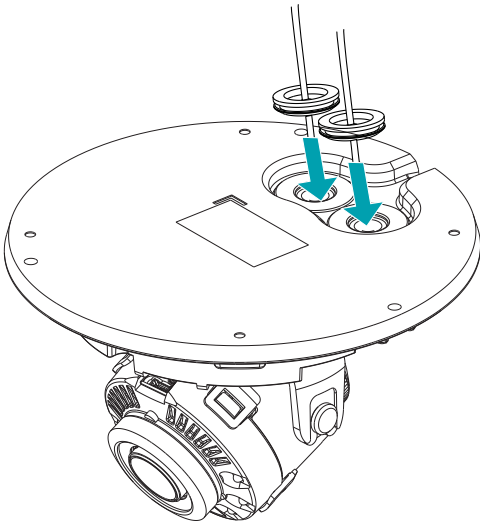

- 5 Attach the enclosed desiccant in the bottom to prevent moisture.

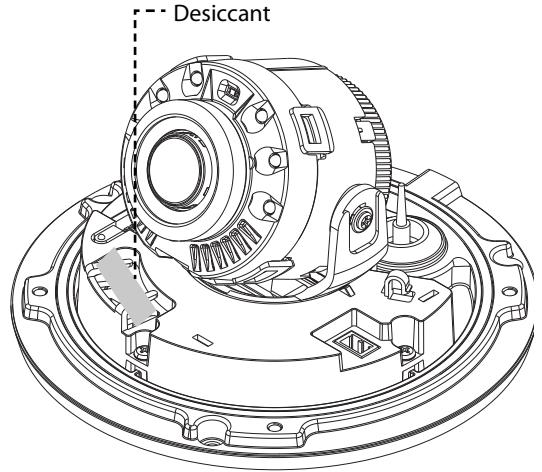

- 6 Use the screws, anchor provided with the camera to secure the install body on a wall or a ceiling.

- Use the provided guide pattern to check the distance between the screws.

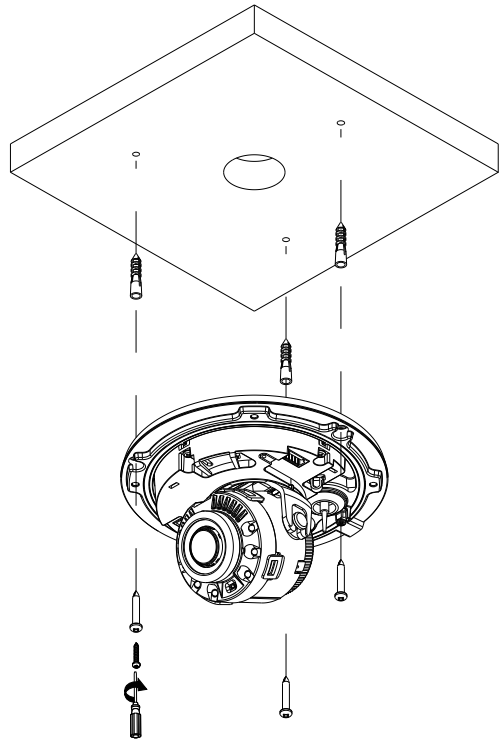

- 7 Connect external devices, the network cable, and the power adapter.
- 8 Adjust the angle. For more information, refer to the **Angle Adjustment**.

Angle Adjustment

The lens can be rotated along three axes.

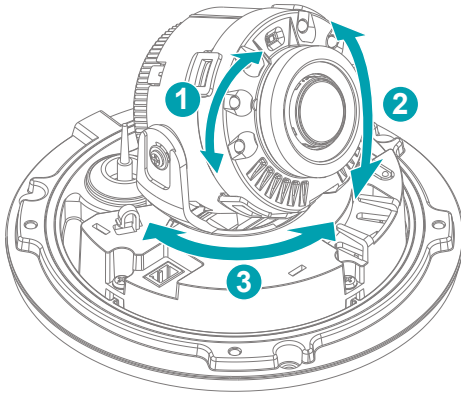

1	Lens Rotation	3	Horizontal Rotation
2	Vertical Rotation		

- **Lens Rotation**

Used to adjust the lens' rotation angle. Turn the lens rotator clockwise or counterclockwise direction.

- **Vertical Rotation**

Used to adjust the lens' vertical angle.

- **Horizontal Rotation**

Used to adjust the lens' horizontal angle. Turn the horizontal rotator in the clockwise or counterclockwise direction.

Closing the Dome Cover

- 1 Attach the double-sided tape to the desiccant first, and attach it to the specified position inside the dome cover as shown below.

Check the location of drain hole and wall/ceiling installation hole.

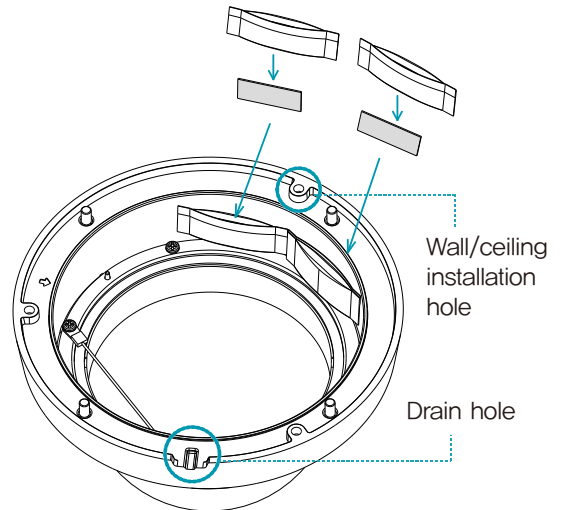

Part 1 – Introduction

- 2 Fasten the screws for the dome cover clockwise using the Allen wrench provided with the camera.

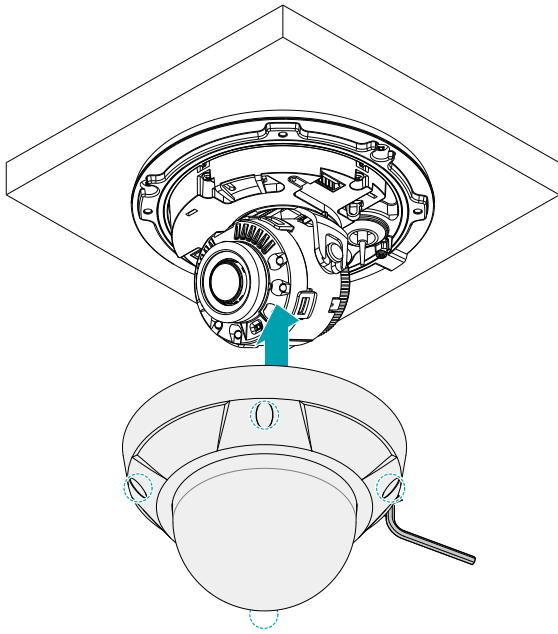

- Remove the protective film inside and outside.

Dimension

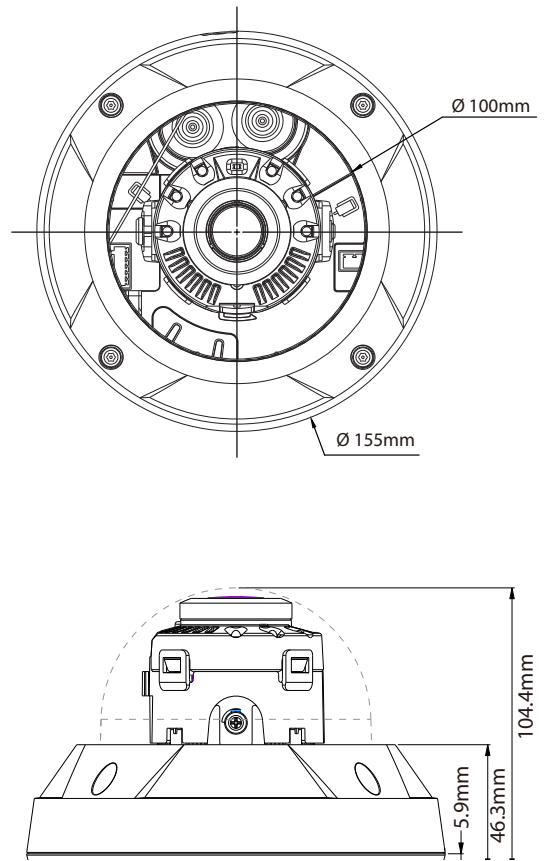

Part 2 - Camera Connection

Use the camera by connecting to DirectIP™ NVR or non DirectIP™ NVR, VMS such as IDIS Solution Suite Compact.

With DirectIP™ NVR-based Layout

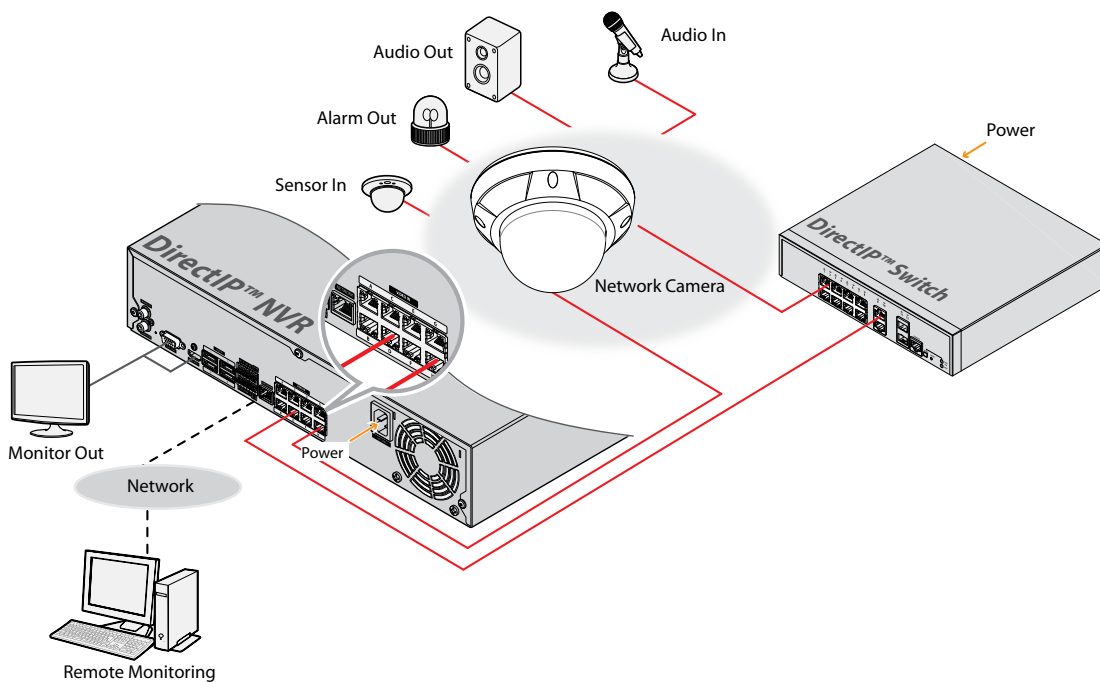

DirectIP™ NVR makes it easy to use cameras without extra network configurations.

Each camera can be controlled via the DirectIP™ NVR setup menu, without any PC.

For detailed camera settings, please see the camera setting pages of DirectIP™ NVR manual.

For users using the camera with DirectIP™ NVR connection, do not need to consider contents in the camera operation manual.

With non DirectIP™ NVR-based Layout

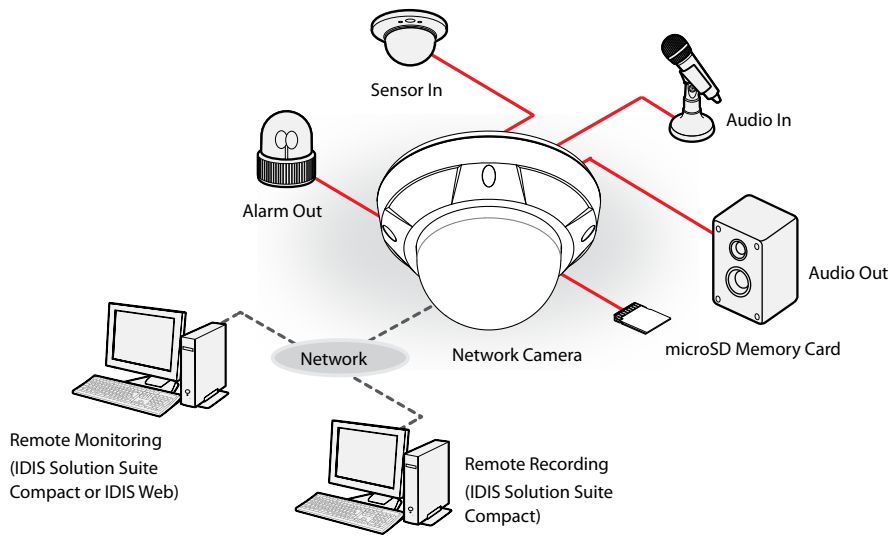

Control the camera over the network from software installed on a computer.
Ideal for using the camera over the network from a remote location.

The contents in the camera operation manual are only for users using the camera with non DirectIP™ NVR connection or VMS connection such as IDIS Solution Suite Compact.

Part 3 - Appendix

Troubleshooting

Problem	Check
The main unit won't turn on.	<ul style="list-style-type: none">• Check the power cable connection. If using a PoE switch to supply power to the camera using an Ethernet cable, check the Ethernet cable connection.• Check the power outlet. If using a PoE switch to supply power to the camera using an Ethernet cable, check the PSE device's power supply.
PoE switch isn't being recognized.	Check the grounding status of the I/O device connected to the camera and the PoE switch. If they are not grounded, ground them and try again.
I can't see Live videos.	<ul style="list-style-type: none">• Check the camera's power status.• Ensure that cables are properly connected to the camera and the lens.• Check the network connection status of the computer and the network camera.
Images are blurry.	<ul style="list-style-type: none">• Make sure the lens is clean. If not, clean it using a soft piece of cloth or a brush.• Make sure the lens is in focus. Adjust the focus during daytime.• If there is too much light coming into the camera or the camera is picking up an overly bright light source, adjust the camera's position/angle accordingly.
Video color appears incorrect.	Check the white balance settings. If using the Auto option, it may take some time for the white balance to be adjusted.
Images are blinking.	If the camera is pointed at the sun or a fluorescent lamp, adjust the camera's angle away.
Lost the admin ID and password and unable to connect to a network camera.	You must perform a factory reset. A factory reset will revert all settings, including network settings, to their factory defaults. After performing a factory reset, make a memo of the admin ID and password as a safety precaution.
Unable to launch IDIS Web.	If the IDIS Web login screen is not loading, check which version of Microsoft Internet Explorer you are using. IDIS Web may not launch properly on versions 8.0 or below.

Specifications



These product specifications may change without prior notice.

Video

Image Sensor	1/2.8" CMOS
Max. Resolution	3840 x 2160
Scanning Mode	Progressive Scan
Lens type	Motorized Vari-focal
Focal Length	f=2.7-13.5mm
Aperture	F=1.8-F3.32
Iris Control	DC Iris
Angular Field of View	Wide : 134.1°(D), 110.6°(H), 57.3°(V) Tele : 37.4°(D), 32.6°(H), 18.3°(V)
Min. Illumination	COLOR : 0.2 lux @ F1.8 B/W : 0.02 lux (IR LED ON)
Dynamic Range	120dB, True WDR
Electronic Shutter Speed	Auto / Manual (1/30 ~ 1/10,000), Anti-Flicker, Slow Shutter (1~1/5, 1/7.5, 1/15)
Day & Night	IR cut filter with auto switch
IR Distance (LEDs)	40m (6ea)
Pan/Tilt Range	Pan: -175° ~ 175°, Tilt: 0° ~ 64°, Rotate: -177° ~ 177°

Network

Video Compression	H.265, H.264(MP), M-JPEG
Bit rate Control	CBR / VBR
Max. Frame Rate	16:9 mode : 30ips(WDR 15ips) : 3840 x 2160(WDR)
Audio Compression	ADPCM-16K, G.726, G.711u-Law, G.711a-Law
Supported Resolution	3840 x 2160, 1920 x 1080, 1280 x 720, 640 x 360
Multi-Video Streaming	Quadruple
Ethernet	RJ45(10/100BASE-T)
Edge Storage* (Optional)	 (Micro SD/SDHC/SDXC memory card (class 6 or higher, max. 256GB))

* An SLC (Single Level Cell) or MLC (Multi Level Cell) card by SanDisk or Transcend is recommended to ensure stable recording performance.

* An SD memory card is a consumable product with a finite service life. Prolonged use will damage the card's memory sectors and result in data loss or memory card failure. Test the SD memory card regularly and replace it whenever necessary.

* microSD Logo is a trademark of SD-3C, LLC.

I/O

Audio In/Out	Line-in 1ea / Line-out 1ea
Alarm In	1 TTL, NC/NO Programmable, 4.3V(NC) or 0.3V(NO) threshold, 5V DC
Alarm Out	1 TTL open collector, Max. load: 30mA, Max. voltage: 5VDC

General

Operating Temperature	-40°C ~ +55°C (-104°F ~ +131°F)
Boot Up Temperature	-20°C ~ +55°C (-4°F ~ +131°F)
Operating Humidity	0% ~ 90%
Power Source	DC12V , PoE (IEEE 802.3af Class 3)
Power Consumption	12V * 1.2A = 14.4W PoE : 12.4W
Approval	FCC, CE, IP67,IK10
External Dimensions (Ø x H)	155mm x 104.4mm (6.10" x 4.09")
Weight (Main Unit)	1.02kg (2.24lb)



IDIS Co., Ltd.

For more information, please visit at
www.idisglobal.com