

©2021 Hangzhou Hikvision Digital Technology Co., Ltd. All rights reserved.

About this Manual

The Manual includes instructions for using and managing the Product. Pictures, charts, images and all other information hereinafter are for description and explanation only. The information contained in the Manual is subject to change, without notice, due to firmware updates or other reasons. Please find the latest version of this Manual at the Hikvision website (<https://www.hikvision.com/>). Please use this Manual with the guidance and assistance of professionals trained in supporting the Product.

HIKVISION and other Hikvision's trademarks and logos are the properties of Hikvision in various jurisdictions. Other trademarks and logos mentioned are the properties of their respective owners.

Disclaimer
TO THE MAXIMUM EXTENT PERMITTED BY APPLICABLE LAW, THIS MANUAL AND THE PRODUCT DESCRIBED, WITH ITS HARDWARE, SOFTWARE AND FIRMWARE, ARE PROVIDED "AS IS" AND "WITH ALL FAULTS AND ERRORS". HIKVISION MAKES NO WARRANTIES, EXPRESS OR IMPLIED, INCLUDING WITHOUT LIMITATION, MERCHANTABILITY, SATISFACTORY QUALITY, OR FITNESS FOR A PARTICULAR PURPOSE. THE USE OF THE PRODUCT BY YOU IS AT YOUR OWN RISK. IN NO EVENT WILL HIKVISION BE LIABLE TO YOU FOR ANY SPECIAL, CONSEQUENTIAL, INCIDENTAL, OR INDIRECT DAMAGES, INCLUDING, AMONG OTHERS, DAMAGES FOR LOSS OF BUSINESS PROFITS, BUSINESS INTERRUPTION, OR LOSS OF DATA, CORRUPTION OF SYSTEMS, OR LOSS OF DOCUMENTATION, WHETHER BASED ON BREACH OF CONTRACT, TORT (INCLUDING NEGLIGENCE), PRODUCT LIABILITY, OR OTHERWISE, IN CONNECTION WITH THE USE OF THE PRODUCT, EVEN IF HIKVISION HAS BEEN ADVISED OF THE POSSIBILITY OF SUCH DAMAGES OR LOSS. YOU AGREE TO USE THIS PRODUCT IN COMPLIANCE WITH ALL APPLICABLE LAWS, AND YOU ARE SOLELY RESPONSIBLE FOR ENSURING THAT YOUR USE CONFORMS TO THE APPLICABLE LAW. ESPECIALLY, YOU ARE RESPONSIBLE, FOR USING THIS PRODUCT IN A MANNER THAT DOES NOT INFRINGE ON THE RIGHTS OF THIRD PARTIES, INCLUDING WITHOUT LIMITATION, RIGHTS OF PUBLICITY, INTELLECTUAL PROPERTY RIGHTS, OR DATA PROTECTION AND OTHER PRIVACY RIGHTS. YOU SHALL NOT USE THIS PRODUCT FOR ANY PROHIBITED END-USES, INCLUDING THE DEVELOPMENT OR PRODUCTION OF WEAPONS OF MASS DESTRUCTION, THE DEVELOPMENT OR PRODUCTION OF CHEMICAL OR BIOLOGICAL WEAPONS, ANY ACTIVITIES IN THE CONTEXT RELATED TO ANY NUCLEAR EXPLOSIVE OR UNSAFE NUCLEAR FUEL-CYCLE, OR IN SUPPORT OF HUMAN RIGHTS ABUSES. IN THE EVENT OF ANY CONFLICTS BETWEEN THIS MANUAL AND THE APPLICABLE LAW, THE LATER PREVAILS.

-  1. The retina blue radiation of the fill light has a CLASS 1 hazard (IEC 62471-2:2009). Please do not stare at the fill light. It may cause damage to the eyes.
- 2. The safe distance between eyes to fill light is 0.2 m.
- 3. Without proper protection (such as wearing sunglasses), when installing or maintaining the equipment, you need to be outside the safe distance or in the area where the light source can't directly illuminate before lighting up the light source.

 This product and - if applicable - the supplied accessories too are marked with "CE" and comply therefore with the applicable harmonized European standards listed under the EMC Directive 2014/30/EU, RE Directive 2014/53/EU, the RoHS Directive 2011/65/EU.



- 1. Install the equipment according to the instructions in this manual.
- 2. To prevent injury, this equipment must be securely attached to the floor/wall in accordance with the installation instructions.

 2012/19/EU (WEEE directive): Products marked with this symbol cannot be disposed of as unsorted municipal waste in the European Union. For proper recycling, return this product to your local supplier upon the purchase of equivalent new equipment, or dispose of it at designated collection points. For more information see: www.recyclethis.info



2006/66/EC (battery directive): This product contains a battery that cannot be disposed of as unsorted municipal waste in the European Union. See the product documentation for specific battery information. The battery is marked with this symbol, which may include lettering to indicate cadmium (Cd), lead (Pb), or mercury (Hg). For proper recycling, return the battery to your supplier or to a designated collection point. For more information see: www.recyclethis.info

1 Appearance

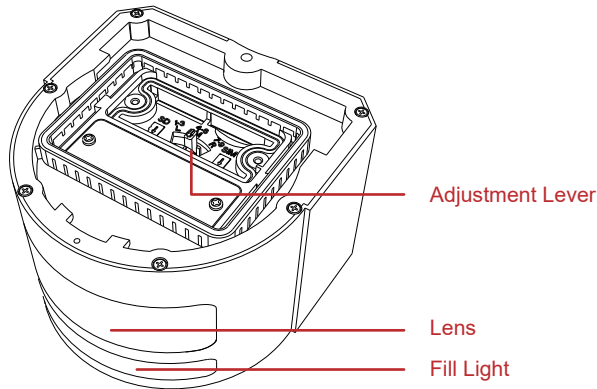

2 Tri-T AM Detector Enrollment

• Enrollment Preparation

Log in to the APP Store, download and install the App.

Power on the security control panel.

Log in the APP and tap the icon "+". Scan the QR code or input the control panel serial No. to add the control panel.

1 Enroll the Peripheral Locally

In the APP, tap the "Enrollment Mode" button on the control panel page to make the control panel enter the enrollment status.

2 Enroll the Peripheral with QR and serial No.

In the APP, tap the icon "+" and scan the QR code or serial No. on the peripheral.

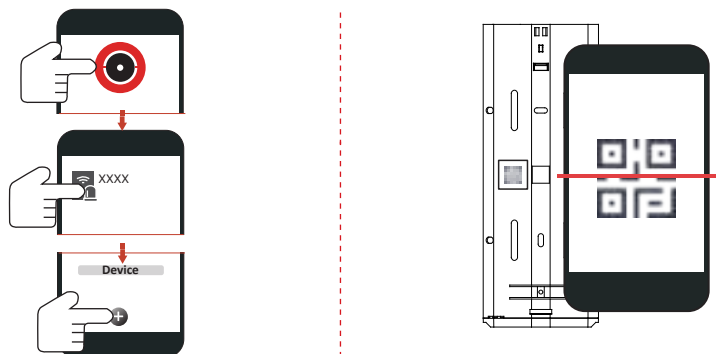

• Enrollment Result

1. Enrollment succeeded: Flash green for 7 times.
2. Check Signal Strength
 - Solid Green for 3 s - Strong Signal
 - Solid Orange for 3 s - Medium Signal
 - Solid Red for 3 s - Weak Signal
 - Flash Red for 6 times - Lost Signal

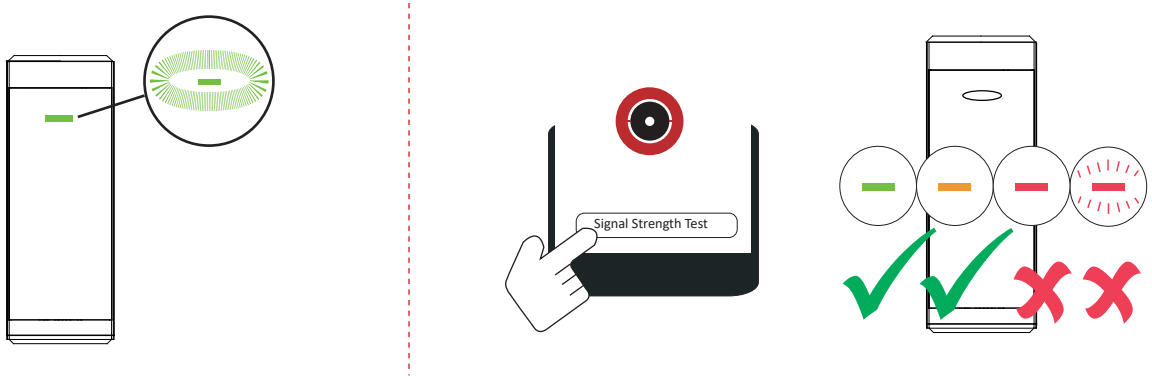

Note: You should ensure the enrollment of the Tri-T AM detector succeeded before the following procedures.

3 Camera Installation and Enrollment

1. Push the top and bottom cover forward and remove it.
2. Remove the screws and open the cover of the camera module.
3. Confirm the rotation scale value of the PIR. Adjust the lever of the cam module to the corresponding position with a screw driver.
4. Put the top cover back and fix it with screws.

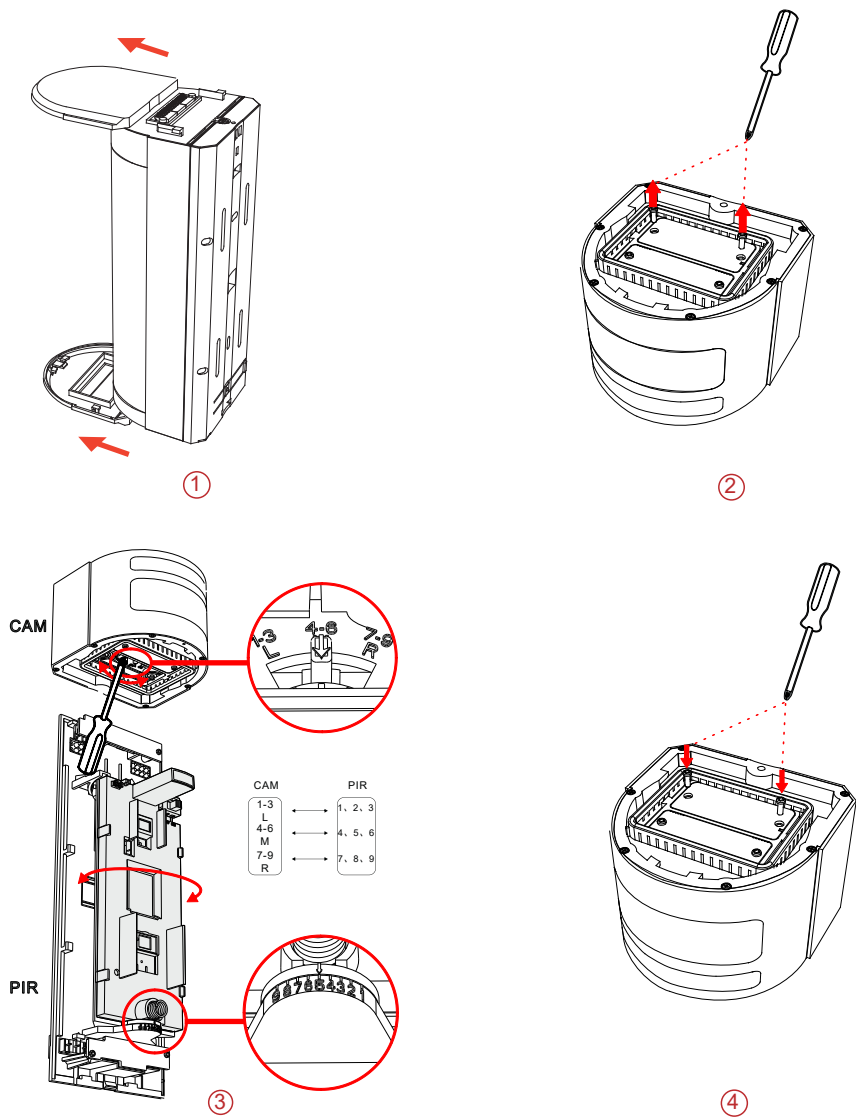

5. On the device list page, tap **Tri-Tech AM Detector**.
Then tap **Add Camera**.
 6. Push and fix the cam module onto the Tri-Tech AM detector.
Check whether the edges of Tri-Tech AM detector and cam module are aligned.
 7. Fix the cam module with the screw.
 8. Put the TPU cover.
- Wait for the module to enroll successfully.

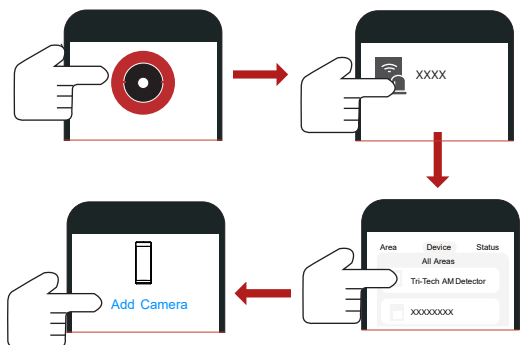

⑤

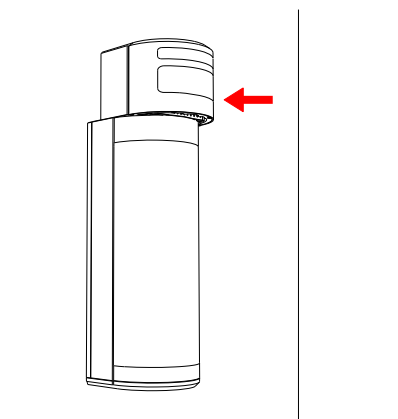

⑥

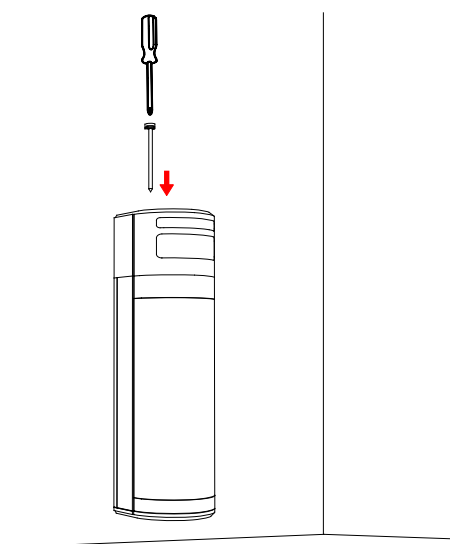

⑦

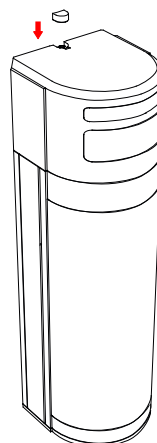

⑧

4 Set Up with App

You can view the device status including temperature, signal intensity, battery level, lid, external input, etc., on the device page. Tap the  button to enter the settings page.

5 Operation Caution and Device Maintenance

- All the electronic operation should be strictly compliance with the electrical safety regulations, fire prevention regulations and other related regulations in your local region.
- Do not drop the device or subject it to physical shock, and do not expose it to high electromagnetism radiation. Avoid the equipment installation on vibrations surface or places subject to shock (ignorance can cause equipment damage).
- Please make sure that the power has been disconnected before you wire, install or dismantle the device.
- If smoke, odors or noise rise from the device, turn off the power at once and unplug the power cable, and then please contact the service center.
- Do not drop the device or subject it to physical shock, and do not expose it to high electromagnetism radiation. Avoid the equipment installation on vibrations surface or places subject to shock (ignorance can cause equipment damage).
- Do not place the device in extremely hot (refer to the specification of the device for the detailed operation temperature), cold, dusty or damp locations, and do not expose it to high electromagnetic radiation.
- The device for indoor use shall be kept from rain and moisture.
- Exposing the equipment to direct sun light, low ventilation or heat source such as heater or radiator is forbidden (ignorance can cause fire danger).
- Do not aim the device at the sun or extra bright places. A blooming or smear may occur otherwise (which is not a malfunction however), and affecting the endurance of sensor at the same time.
- Improper use or replacement of the battery may result in hazard of explosion. Replace with the same or equivalent type only. Dispose of used batteries according to the instructions provided by the battery manufacturer.
- Do not expose the device to the corrosive gas. Otherwise the equipment damage may occur.
- Do not expose the device to the explosive situation.

6 Specification

Field Angle	137.2°(H), 80.1°(V)
Image Type	JPEG
Resolution	640*480,320*240,160*120
Fill Light	Infrared Light
Fill Range	15m
Day/Night Switch	Auto
Power Supply	3 VDC
Operation Temperature	-25 °C to 60 °C (-13 °F to 140 °F)
Storage Temperature	-25 °C to 60 °C (-13 °F to 140 °F)
Operation Humidity	10% to 90%
IP Rate	IP66
Dimension(WxHxD)	74.1mm x 72.35mm x 53mm
Weight	155g