

AXIS Q2802-E Bispectral Camera

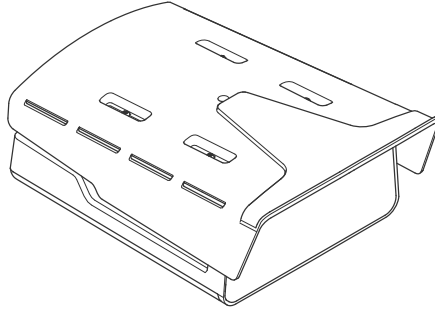

Impact on warranty

This product is approved for repaint by Axis, provided that you follow the instructions in this document and at axis.com/warranty-implication-when-repainting.

Risks with repainting

There are several risks when disassembling or assembling an Axis product. Training of operators and the use of correct tools mediates some of the problems but they can never be fully avoided. Some of the risks include:

ESD Damage – Always handle the product in an ESD safe environment. Even if precautions are taken there is always a risk of ESD damage. The damage can remain undetected and cause problems during the lifetime of the equipment.

Dust contamination – Opening a camera may expose the lens and sensor to dust or paint. Dust will affect the optical performance. Lenses need to be disassembled in a dust-free environment, preferably a cleanroom.

Paint overspray – Masking the different components of the equipment is critical. Failure to mask sensitive areas can cause problems when assembling the equipment. Areas not painted at the factory or which have a different surface treatment than the parts to be painted (threads, ground and electrical contact surfaces) must also be masked to ensure function.

Repaint the product

Preparations

- If applicable, disassemble the device according to the instructions in this document.
- Clean all parts that will be repainted thoroughly to remove grease, dust, or oil.
- To ensure reassembly and functionality of the product, mask any openings (for example for screws, LED indicators, or microphones) before you paint.
- To avoid unwanted reflections, mask the inside of the weathershield before you paint.

Material used in this product

- The weathershield and top cover are plastic.
- The bottom chassis is powder coated.

Pretreatment of parts

Depending on the part material and type of coating applied at the factory, pretreatment might be necessary for the new coating to adhere well. Before you apply a new coating, we recommend the following pretreatment:

1. If necessary, roughen up the surface with a light sandpaper or similar to increase adhesion. Alternatively, remove the original coating down to the base material.
2. Clean the parts properly to remove oil, grease, and dust.
3. If necessary, apply a primer layer suitable for the specific material, to increase adhesion to the parts. For metal parts on outdoor products, we recommend a primer to improve corrosion resistance.

We recommend pretreatment of parts that are:

- powder-coated
- wet-painted
- anodised
- chromated
- stainless steel
- other metal
- plastic

Disassembly

Disassemble the housing

1. Remove the four T20 screws (1) and the bottom chassis (2).
2. Disconnect the safety wire.
3. Remove the top cover (3).
4. Remove the four T20 screws (5) and the weathershield (4).

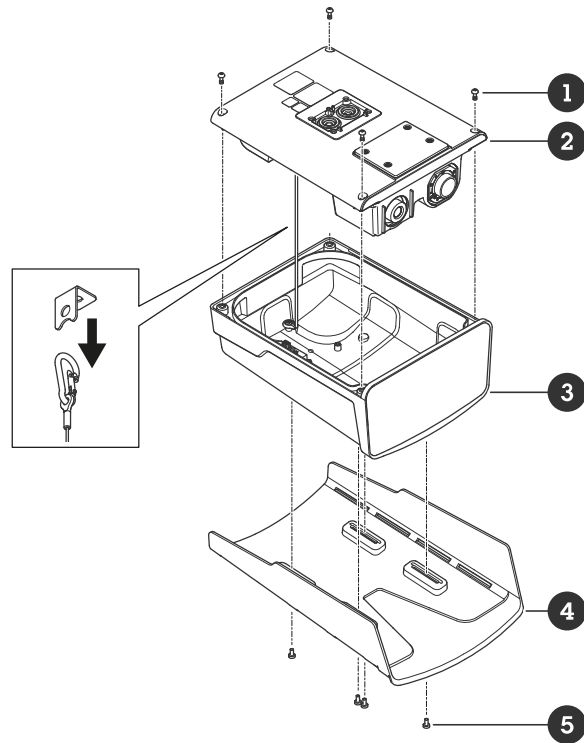

Masking

Masking the top cover

Mask the following parts of the top cover:

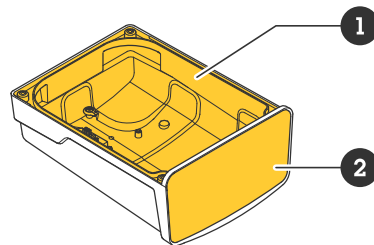

- 1 Inside and screw holes (4x)
- 2 Front window

Masking the bottom chassis

Mask the following parts of the bottom chassis:

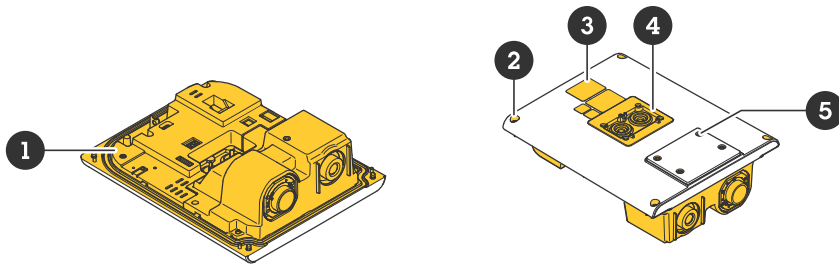

- 1 Top side
- 2 Screw holes (4x)
- 3 Label
- 4 Mount surface
- 5 Screw holes (4x)

Masking the weathershield

Mask the black part (1) of the weathershield.

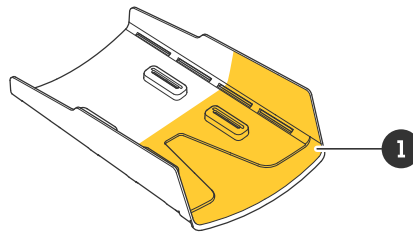

Repainting

1. Apply a thin and even layer of spray paint according to the instructions of the paint manufacturer.
2. Let the paint dry.
3. To get a better coverage and clearer color, apply a second layer of spray paint.
4. When the paint is dry, remove the masking and reassemble the product.

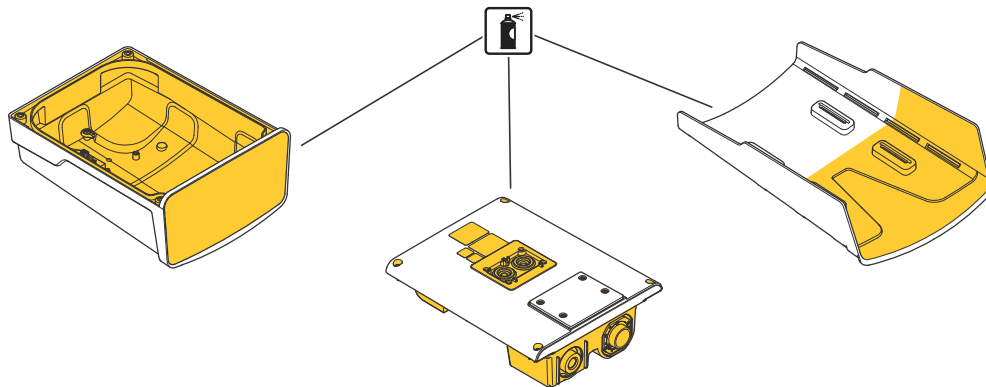

Reassembly

Reassemble the product.

For more information, see the Installation Guide available at axis.com

T10231263

2026-05 (M1.7)

© 2025 Axis Communications AB