

VLS-LSM-CXT

[QUICKSTART GUIDE]

EXTERIOR LONG RANGE ETHERNET & HIGH POWER POE

LONGSPAN[®]
MAX XT



[WHAT'S IN THE BOX]

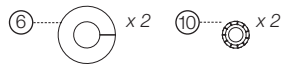
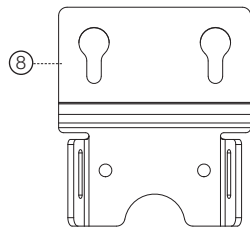
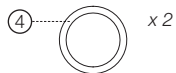
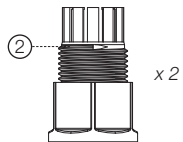
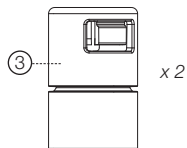
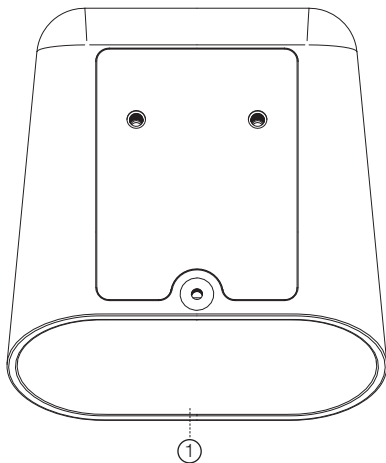

LIST OF CONTENTS

- ① LONGSPAN Max XT Device
Enclosure: powder coated aluminium
- ② Cable Gland Body
UV Stabilised Nylon
- ③ Cable Gland Nut (with Conduit Adaptor)
UV Stabilised Nylon
- ④ Cable Gland O-ring - Red
Pre-assembled into Cable Gland Body
- ⑤ Cable Gland Grommet - Black
*Pre-assembled into Cable Gland Body
For 4.7 - 6.5mm cables*
- ⑥ Cable Gland Grommet - Green
For 6.0 - 7.8mm cables
- ⑦ Cable Gland Grommet - Red
For 7.0 - 9.0mm cables
- ⑧ Mounting Plate
Anodised aluminium
- ⑨ Screws - Mounting & Grounding
M4 x 8mm - DIN 933SZ - Aluminium
- ⑩ Toothed Washer
M4 - External Toothed - Zinc Plated Steel
- ⑪ Nylon Washer
For use with self tapping screws
- ⑫ LONGSPAN Max XT Quickstart Guide

[FITTING CONNECTORS]

GASKET	CABLE	EXAMPLE CABLE
Black	4.7 - 6.5mm	Cat 5e UTP, Cat 6 UTP
Green	6.0 - 7.8mm	Cat 5e, Cat 6 STP, Cat 6a
Red	7.0 - 9.0mm	Double Shielded, old Cat 6a

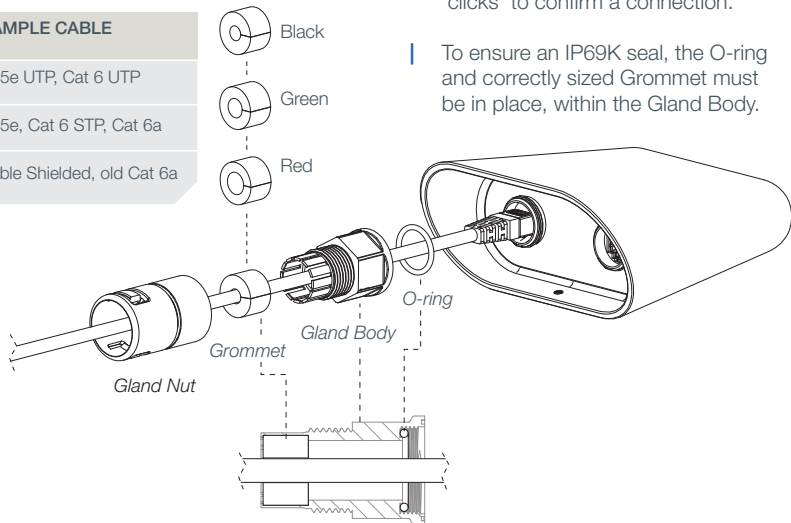

- ② | Tighten the Cable Gland Body onto the threaded RJ45 port. This seals the O-ring.

*Tighten the gland firmly, by hand.
Do not use tools for tightening.*

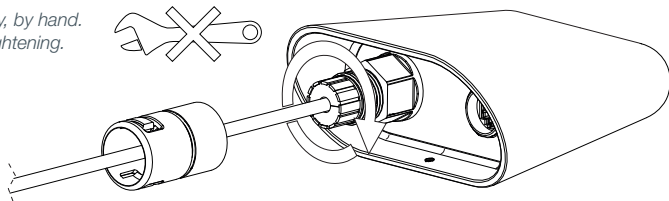

- ③ | Tighten the Gland Nut onto the Body. This seals the Grommet around the cable.

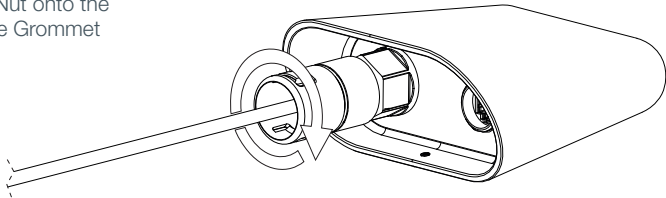

[MOUNTING PLATE]

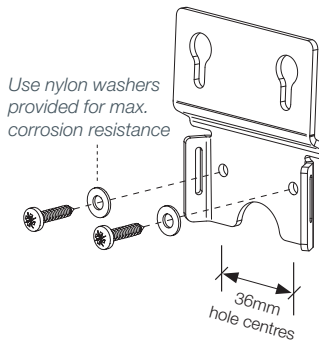

- | Mounting to flat surfaces:
Maximum screw size 3.5mm (#6)

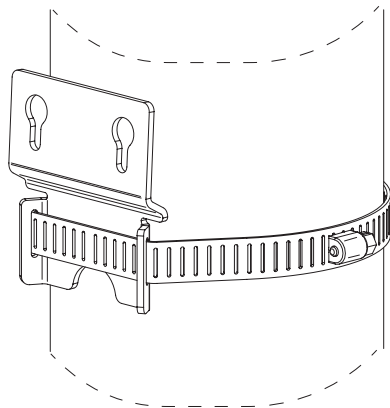

- | Mounting to poles:
Maximum band width 12.5mm (1/2")

MOUNTING THE DEVICE

①

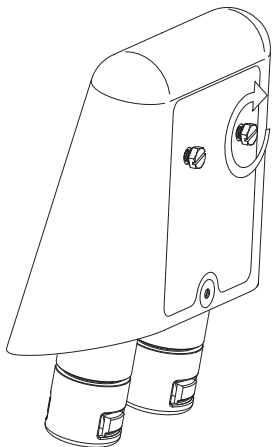

Manually adjust the mounting screws to allow for the mounting bracket thickness.

LONGSPAN Max XT should always be installed this way up.

②

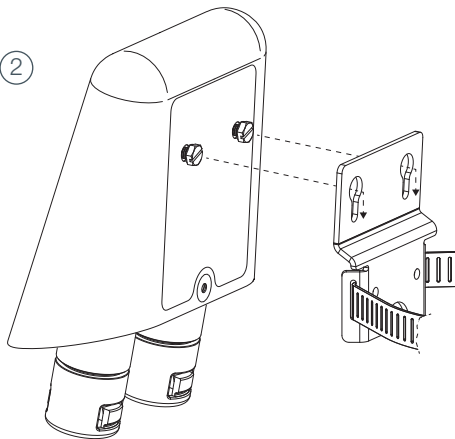

Mount the device to the bracket to assess the fit. Repeat until a tight fit is achieved. In applications subject to vibration, use a light to medium threadlocker on the mounting screws.

www.veracityglobal.com | 07

CONDUIT ADAPTOR

- | The Conduit Adaptor section of the Cable Gland Nut is designed for use with 20mm (ISO) or 1/2-inch (US) flexible conduit.
- | It is compatible with various types with an outer diameter ranging 20mm - 21.5mm

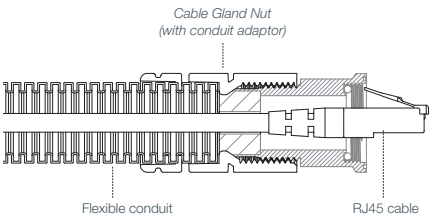

- | With the POE cable connected to the device, firmly push the conduit into the Conduit Adaptor until it's fully inserted and held securely in place.

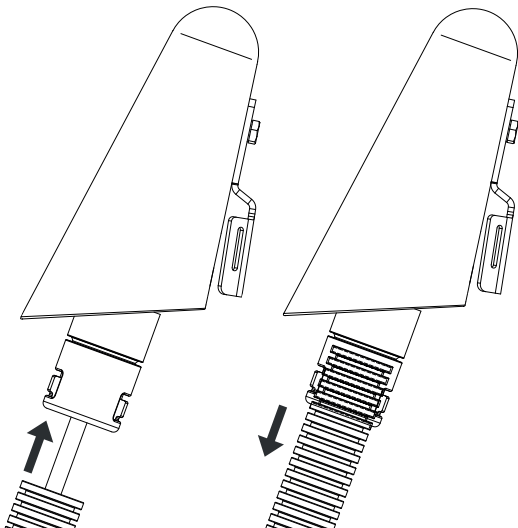

GROUNDING THE DEVICE

Grounding the LONGSPAN Max XT case is generally NOT required.

Therefore the following steps can be bypassed unless grounding is specifically required due to local conditions or specifications.

If grounding IS required, carry out the following steps:

- | The grounding point is designed for use with M4 ring terminals and lugs. Assemble in the order shown.
- | Always use the toothed washer to maximise electrical connection and prevent loosening.
- | Always use plated terminals. Never use bare copper terminals.

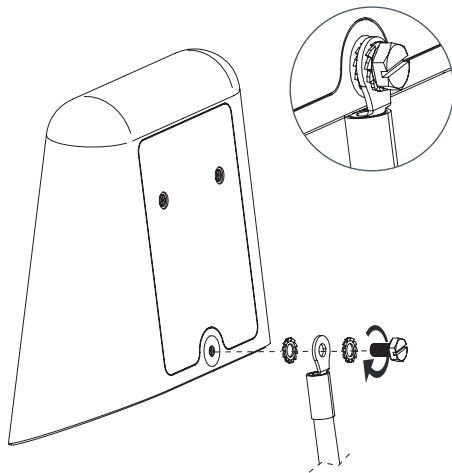

Recommendation: once assembled, cover the grounding components in a waterproof, dielectric grease. This will form a protective barrier to help protect against galvanic corrosion.

[DIMENSIONAL DRAWINGS]

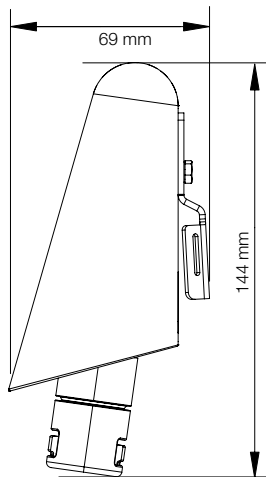
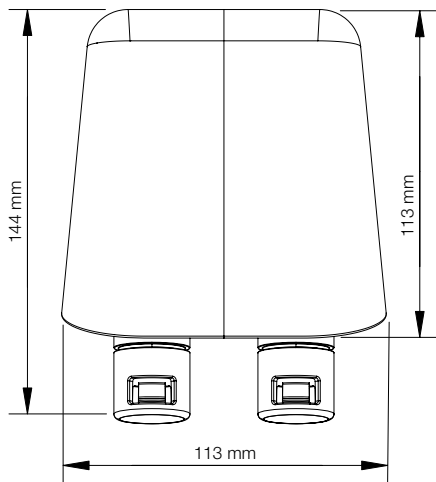

VLS-LSM-CXT POE RANGE

POE DEVICE POWER	Cat6	Cat5e
71 WATTS	200m (656ft)	150m (492ft)
62 WATTS	235m (770ft)	180m (590ft)
51 WATTS	290m (950ft)	230m (754ft)
40 WATTS	390m (1,279ft)	310m (1,017ft)
25 WATTS	570m (1,870ft)	450m (1,476ft)

POE Ranges are approximate

VLS-LSM-CXT DATA RANGE

CABLE TYPE	Cat6	Cat5e
DATA RANGE 100Base-TX	820m (2,690ft)	690m (2,263ft)
DATA RANGE 10Base-T	1,050m (3,450ft)	950m (3,100ft)

POE REFERENCE TABLE

POE CLASS	IEEE STANDARD	POE POWER AT PSE	POE POWER AT PD
0	802.3af	15.4W	12.95W
1	802.3af	4W	3.84W
2	802.3af	7W	6.49W
3	802.3af	15.4W	12.95W
4	802.3at	30W	25.5W
5	802.3bt	45W	40W
6	802.3bt	60W	51W
7	802.3bt	75W	62W
8	802.3bt	90W	71.3W

PSE = Power Sourcing Equipment PD = Powered Device

[COMPATIBILITY]

- | LONGSPAN Max XT devices are compatible with all standard LONGSPAN Base 8, LONGSPAN Base and LONGSPAN Max Base devices.

Details of distances, and available POE are shown in the tables on Page 11.

[POE POWER BUDGET LEDS]

- | The POE power budget is the measured total available power for POE devices powered by the LONGSPAN Max XT device.

POE power is limited by the cable type, cable distance and power injected at the Base end. See table for POE power vs distance.

[CONNECTIONS & LEDS]

Ethernet and POE to Camera/Device

10Base-T/100Base-TX, auto speed, crossover, full duplex. IEEE 802.3af/at/bt compliant.

LED	FUNCTION
RJ45 Green	On = POE enabled Blink = POE error Off = POE device not detected. Ethernet only
RJ45 Yellow	On = link Blink = activity

[CONNECTIONS & LEDS]

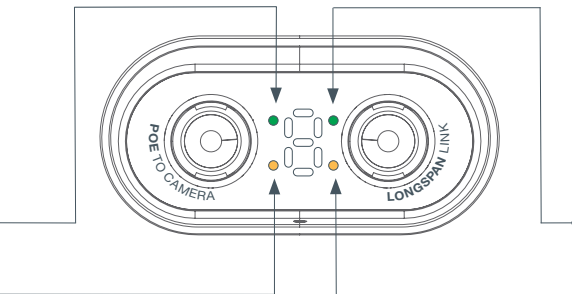

LONGSPAN Link and 802.3bt POE Input

LED	FUNCTION
RJ45 Green	On = 100Mbps Flash = 10Mbps Off = no link
RJ45 Yellow	On = link Blink = activity

POWER & ERROR LED INDICATOR

The 7 Segment Power and Error LED indicators are shown here. The LED indicator for Power shows a green 'P' and the Error Codes show a red 'E' for 2 seconds before displaying the relevant number for 2 seconds and then the code repeats.

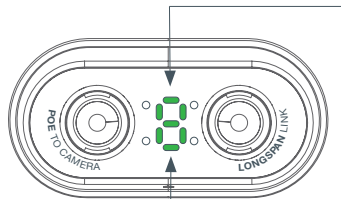

GREEN LED	POWER
P1	5W
P2	10W
P3	20W
P4	30W
P5	40W
P6	50W
P7	60W
P8	70W

RED LED	ERROR CODES
E1	POE Power Draw Exceeded
E2	POE Power too Low. Voltage Disabled
E3	POE to Camera Overload
E4	POE to Camera Short
E5	POE to Camera Signature Error
E6	POE over LONGSPAN Enabled but No Link
E7	Cable Wiring Error (connection refused)
E8	Inferior Equipment (connection refused)

APPLICATION DIAGRAM WITH 802.3BT POE TRANSMISSION

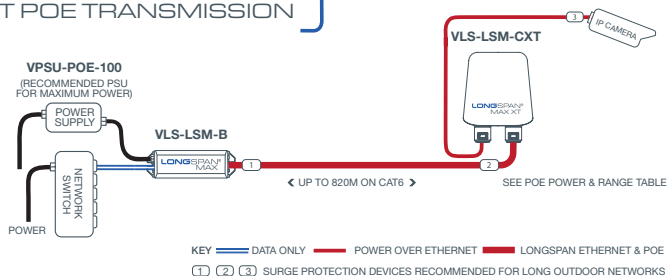

Connect LONGSPAN Max Base to LONGSPAN Max XT Camera and then to a POE camera, or other POE device.

The LONGSPAN Max Base device may be powered either by a POE network switch or for maximum power, by a separate Veracity 56-57V DC power supply.

Cat6 cable is recommended for increased POE delivery at distance.

The LONGSPAN Max Base device can output a maximum of 90W POE depending upon the optional PSU.

See LONGSPAN Max XT Tables on Page 11 or the datasheet tables for distance vs power levels.

LONGSPAN Max XT will only deliver >25W POE to 802.3bt compatible IP cameras or other devices.

[SURGE PROTECTION]

Any LONGSPAN network design for outdoor applications must incorporate the appropriate level of surge protection to avoid invalidation of warranty due to electrical storm damage. It is the responsibility of the system installer to ensure the correct level of protection.

All Veracity products have been independently tested to verify their resilience to the stringent immunity levels of international standards. Users should note that no electronic equipment can be guaranteed to be completely protected at levels beyond the defined standard; therefore product warranty cannot include damage to products which has been caused by surges exceeding those of the standards specified, for example lightning strike activity.

It is the user's responsibility to implement relevant surge protection measures, as appropriate to the installation. This may include the fitting of additional surge protection devices where required.

[FCC CERTIFICATION]

This device complies with Part 15 of the FCC Rules.

Operation is subject to the following two conditions: (1) this device may not cause harmful interference, and (2) this device must accept any interference received, including interference that may cause undesired operation.

NOTE: This equipment has been tested and found to comply with the limits for a Class B digital device, pursuant to Part 15 of the FCC Rules.

These limits are designed to provide reasonable protection against harmful interference when the equipment is operated in a commercial environment. This equipment generates, uses, and can radiate radio frequency energy and, if not installed and used in accordance with the instruction manual, may cause harmful interference to radio communications.

Operation of this equipment in a residential area is likely to cause harmful interference in which case the user will be required to correct the interference at their own expense.

Veracity UK Ltd. Prestwick International Aerospace Park, 4 Dow Road, Prestwick, KA9 2TU. UK

Veracity's Authorised Representative in the EU (as required by EU law for CE marked goods) is: Comply Express Unipessoal Limitada, StartUp Madeira, EV141, Campus da Penteadá, 9020 105 Funchal, Portugal.

© Veracity UK Ltd 2023 QSG DV1.6 EN

LONGSPAN Max XT® is a registered trademark of Veracity UK Ltd

